

**Power suppliers:**

- rectifiers,
- Power Factor
- voltage multipliers



---

---

---

---

---

---

---

---



**Transformer parameters**

- Power (single phase up to 3kW)
- Nominal voltage 230V +10% -10%
- Frequency 50Hz
- Transformer parameters:
  - Turn ratio (secondary voltage and current)
  - Idle current
  - Isolation breakdown voltage
  - Dimensions, weight
  - temperature



---

---

---

---

---

---

---

---



**Types of transformers**  
-most popular

- Cores: EI type (shell), roll-up core (strip construction) , toroidal (roll-up ring-shape core, strip construction)
- Core Materials
  - Silicon steel,
  - permalloy



---

---

---

---

---

---

---

---



---

---

---

---

---

---

---

---

**transformers**  
[voltage / turn]

$$\frac{U}{z} = \sqrt{2}\pi f B_{\max} S$$

---

---

---

---

---

---

---

---

**Transformers - power vs. type**

S[cm <sup>2</sup> ]@P[W]	core	B <sub>max</sub> [T]
$S \approx 1,25 \cdot \sqrt{P_1}$	Hot rolled steel sheet, EI core	1T
$S \approx 1,1 \cdot \sqrt{P_1}$	Cold rolled steel sheet EI core	1.1T
$S \approx \sqrt{P_1}$	Cold rolled steel sheet wound core	1.5T
$S \approx 0.8 \cdot \sqrt{P_1}$	Cold rolled steel sheet Toroid	1.6T

---

---

---

---

---

---

---

---

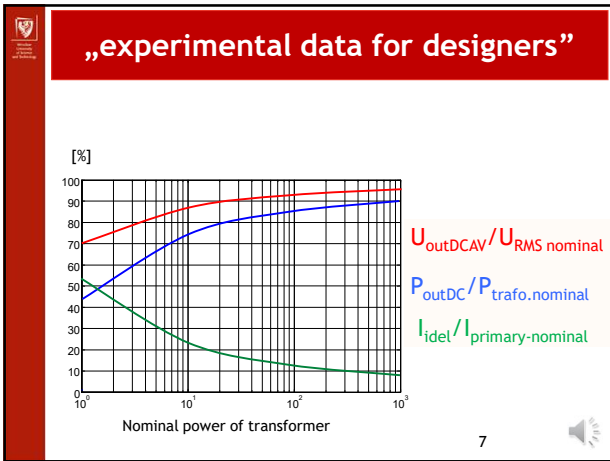

---

---

---

---

---

---

---

---

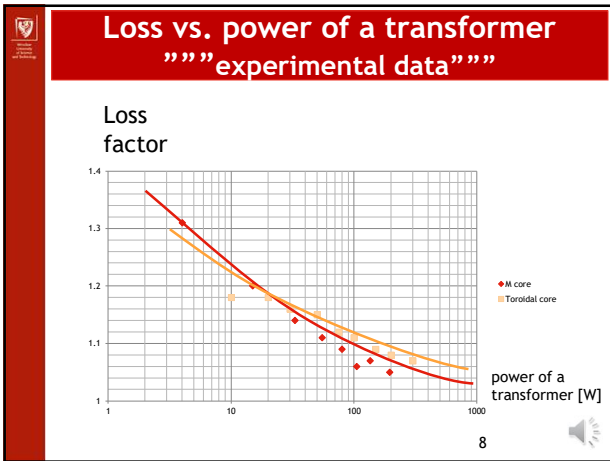

---

---

---

---

---

---

---

---

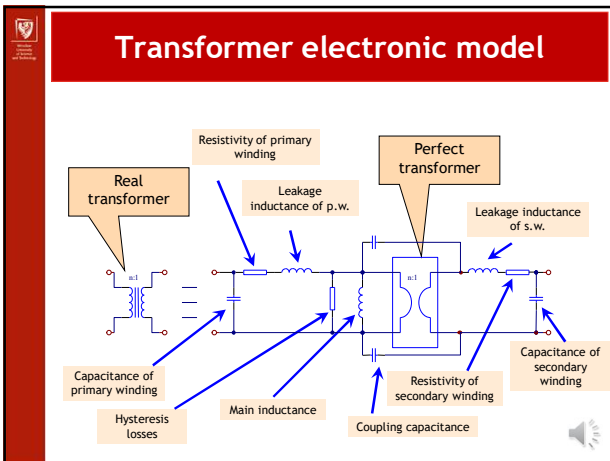

---

---

---

---

---

---

---

---

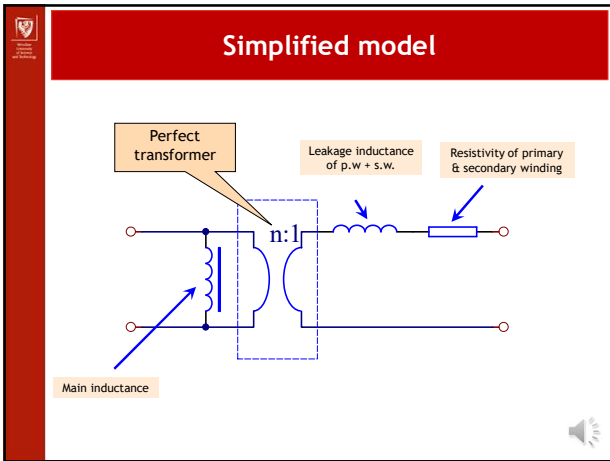

---

---

---

---

---

---

---

---

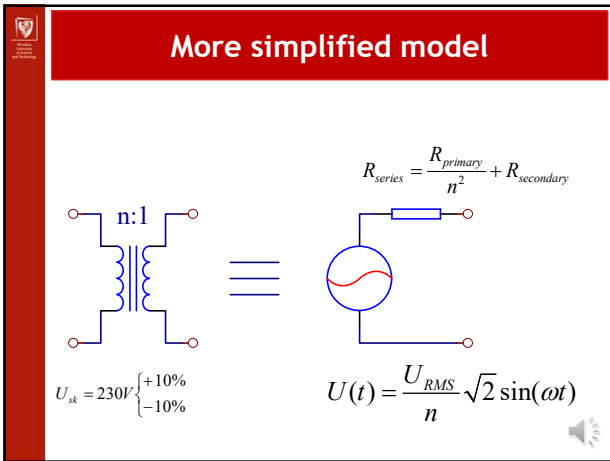

---

---

---

---

---

---

---

---

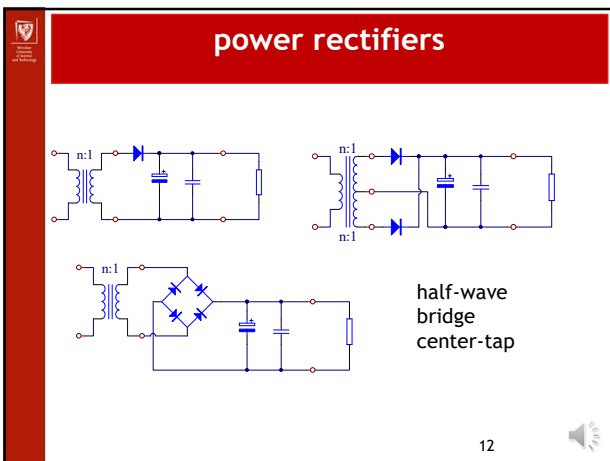

---

---

---

---

---

---

---

---

### half-wave

Speaker icon

---

---

---

---

---

---

---

---

### Center-tap

Speaker icon

---

---

---

---

---

---

---

---

### bridge

Speaker icon

---

---

---

---

---

---

---

---

### Rectifier - resistive load

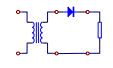

Current and voltage  
across resistive load

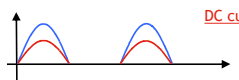

DC current is present!!!

$$I_{AV} = \frac{U_{AV}}{R_0} \quad U_{AV} = \frac{\sqrt{2}}{\pi} E_{RMS} \quad U_{RMS} = \frac{E_{RMS}}{2}$$

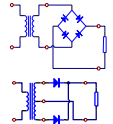

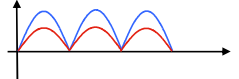

$$U_{AV} = \frac{2\sqrt{2}}{\pi} E_{AV} \quad I_{AV} = \frac{U_{AV}}{R_0} \quad U_{RMS} = E_{RMS}$$

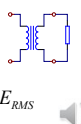

---

---

---

---

---

---

---

---

---

---

---

---

### Voltage and current for half-wave rectifier

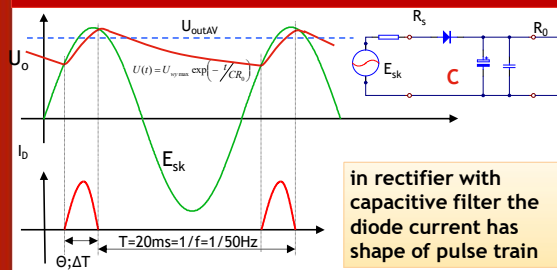

$U(t) = U_{outAV} \exp(-t/CR_0)$

$T = 20ms = 1/f = 1/50Hz$

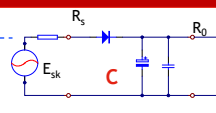

in rectifier with capacitive filter the diode current has shape of pulse train

17

---

---

---

---

---

---

---

---

---

---

---

---

### Half wave rectifier with a capacitive filter

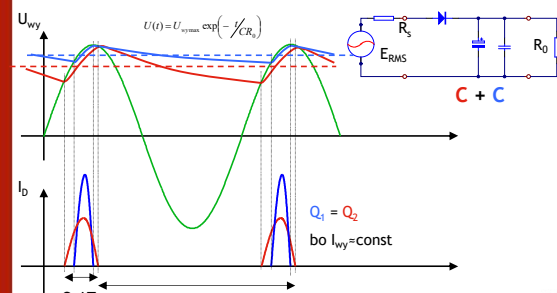

$U(t) = U_{outAV} \exp(-t/CR_0)$

$T = 20ms = 1/f = 1/50Hz$

$Q_1 = Q_2$   
so  $I_{wy} = const$

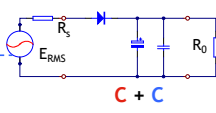

---

---

---

---

---

---

---

---

---

---

---

---

### Basic relations

Maximum idle voltage:

$$U_{\max} \approx \sqrt{2}E_{RMS} - U_F \approx \sqrt{2}E_{RMS}$$

ripples:

$$U_{rip.pp} \approx \frac{Q}{C} = \left( \frac{U_{\max}}{R_0} \right) \frac{T}{C} = \frac{U_{\max}}{fR_0C} \approx \frac{I_{AV}}{fC}$$

*How to figure out this relationship!*



---

---

---

---

---

---

---

---

### Full wave rectifier

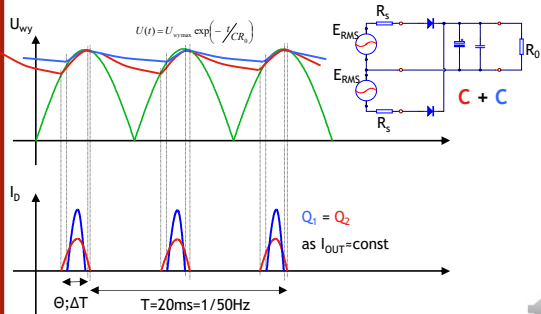

*How to figure out this relationship!*



---

---

---

---

---

---

---

---

### Basic relations

Maximum idle voltage:

$$U_{\max} \approx \sqrt{2}E_{RMS} - U_F$$

bridge:

$$U_{\max} \approx \sqrt{2}E_{RMS} - 2U_F$$

ripples:

$$U_{rip.pp} \approx \frac{Q}{C} = \frac{I_{AV} T/2}{C} = \frac{I_{AV}}{2fC}$$

*How to figure out this relationship!*



---

---

---

---

---

---

---

---

### „surge current”

$$I_{Dmaxmax} = \frac{\sqrt{2}E_{sk}}{R_s}$$

---

---

---

---

---

---

---

---

### half-wave rectifier

for  $U_{rpp}/U_{outAV} < 10\%$

No-load voltage	$U_{outMax} = \sqrt{2}E_{RMS} - 2U_F$
On-load voltage ( $C=\infty$ )	$U_{outAV} = U_{outMax} \left(1 - \sqrt{\frac{R_s}{R_L}}\right)$
Peak revers voltage	$U_{Dmax} = 2\sqrt{2}E_{sk}$
Mean diode current	$I_{Dmean} = I_{outAV}$
Repetitive diode current	$I_{Dmax} = U_{outAV} / \sqrt{R_s R_L}$
Ripple voltage (peak to peak)	$U_{rp} = \frac{I_{outAV}}{fC} \left(1 - \sqrt{\frac{R_s}{R_L}}\right)$
Minimum output voltage	$U_{outMin} = U_{outAV} - \frac{2}{3}U_{rp}$

23

---

---

---

---

---

---

---

---

### bridge rectifier

for  $U_{rpp}/U_{outAV} < 10\%$

No-load voltage	$U_{outMax} = \sqrt{2}E_{RMS} - 2U_F$
On-load voltage ( $C=\infty$ )	$U_{outAV} = U_{outMax} \left(1 - \sqrt{\frac{R_s}{2R_L}}\right)$
Peak revers voltage	$U_{Dmax} = \sqrt{2}E_{sk}$
Mean diode current	$I_{Dmean} = \frac{1}{2} I_{outAV}$
Repetitive diode current	$I_{Dmax} = U_{outAV} / \sqrt{2R_s R_L}$
Ripple voltage (peak to peak)	$U_{rp} = \frac{I_{outAV}}{2fC} \left(1 - \sqrt{\frac{R_s}{2R_L}}\right)$
Minimum output voltage	$U_{outMin} = U_{outAV} - \frac{2}{3}U_{rp}$

24

---

---

---

---

---

---

---

---

### center-tap rectifier

for  $U_{rip}/U_{OUTAV} < 10\%$

No-load voltage	$U_{outMax} = \sqrt{2}E_{RMS} - U_F$
On-load voltage ( $C=\infty$ )	$U_{outV} = U_{outMax} \left(1 - \sqrt{\frac{R_s}{2R_s}}\right)$
Peak revers voltage	$U_{Dmax} = 2\sqrt{2}E_{ak}$
Mean diode current	$I_{Dmean} = \frac{1}{2} I_{outAV}$
Repetitive diode current	$I_{Dmax} = U_{outAV} / \sqrt{2R_s R_L}$
Pipple voltage (peak to peak)	$U_{pp} = \frac{I_{outAV}}{2fC} \left(1 - \sqrt{\frac{R_s}{2R_s}}\right)$
Minimum output voltage	$U_{outMin} = U_{outAV} - \frac{2}{3} U_{pp}$

25

---

---

---

---

---

---

---

---

---

---

### Main parameters

- Assumed:
  - $E_{RMS} = U_{RMS} / n$  (turn ratio)
  - $R_s$  - series resistivity
  - $U_F$  - forward diode voltage
- calculated
  - $U_{OUTRMS}; U_{OUTAV}; U_{OUTMAX}; U_{OUTMIN}; U_{rip}$
  - $I_{DAV}; I_{DRMS}; I_{DMAX}; I_{OUTAV}$
  - $\Theta; \Delta T$  - flow angle; conducting time
  - $k_t = U_{rip,pp} / U_{OUTAV}$  - ripples coefficient
  - $\eta_u = U_{OUTAV} / E_{RMS}$  - voltage efficiency

---

---

---

---

---

---

---

---

---

---

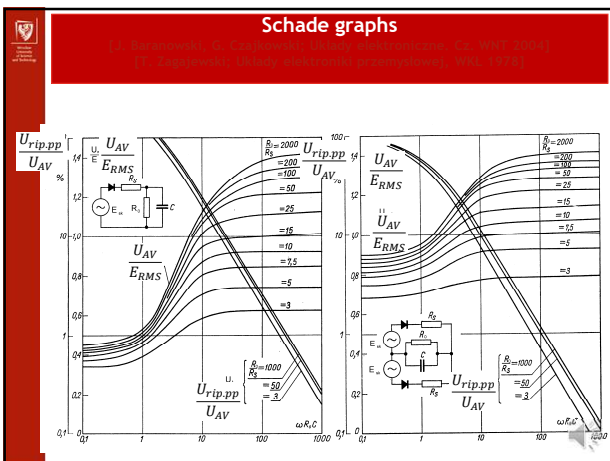

---

---

---

---

---

---

---

---

---

---

### Crest & Wave Form factors

$$CF = \frac{I_{MAX}}{I_{RMS}}$$

Crest Factor -  
For sin = 1,41 =  $\sqrt{2}$

$$FF = \frac{I_{RMS}}{|I|_{AV}}$$

Wave Form Factor -  
For sin = 1,11 =  $\pi/2\sqrt{2}$

---

---

---

---

---

---

---

---

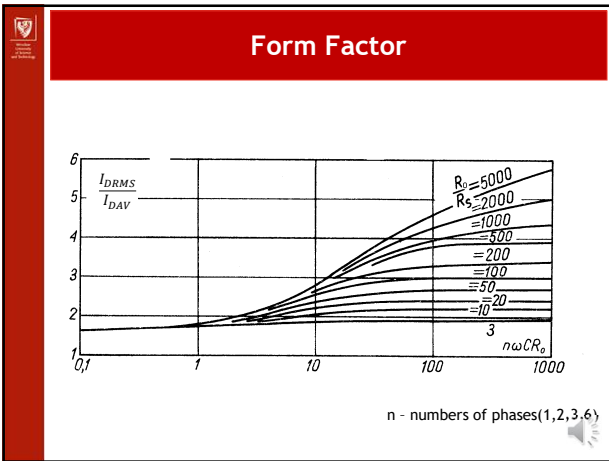

---

---

---

---

---

---

---

---

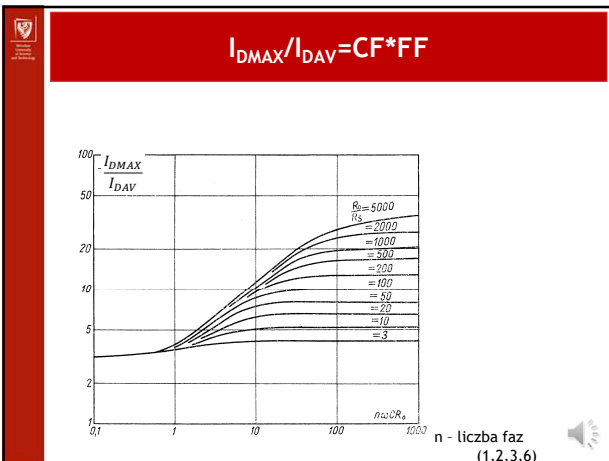

---

---

---

---

---

---

---

---

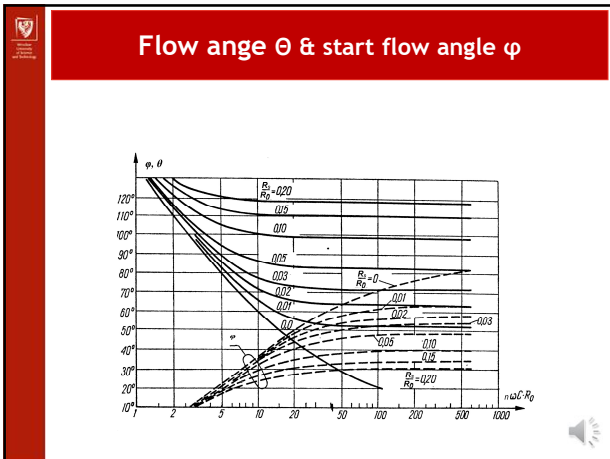

---

---

---

---

---

---

---

---

---

---

### For $\omega R_0 C \gg 1$ i $R_0 \gg R_s$

When C increases

- Ripples fall down  $\sim 1/nfCR_0$  !!!!
- Flow angle decrease (diode conducting time)
  - peak current increase
  - RMS diode & transformer currents increase (heating up)

---

---

---

---

---

---

---

---

---

---

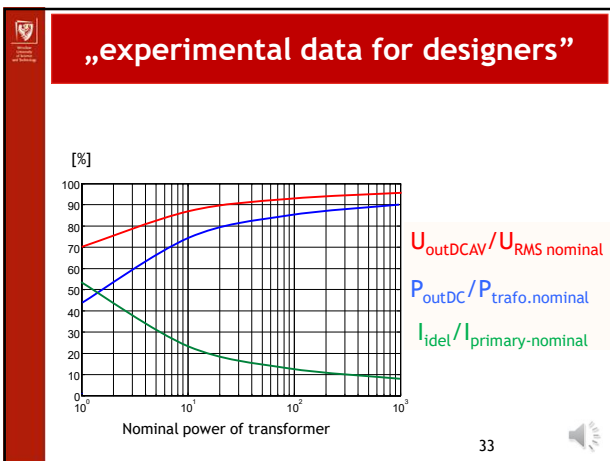

---

---

---

---

---

---

---

---

---

---

### RMS of pulse

$I_{AV} = 1A$   
 $I_{RMS} = \sqrt{\frac{1}{T} \int_0^T i^2(t) dt} = 1A$   
 $CF = 1; FF = 1;$

$I_{AV} = 1A$   
 $I_{RMS} = \sqrt{\frac{1}{T} \int_0^T i^2(t) dt} = \sqrt{2}A$   
 $CF = \sqrt{2}; FF = \sqrt{2};$

$I_{AV} = 1A$   
 $I_{RMS} = \sqrt{\frac{1}{T} \int_0^T i^2(t) dt} = 2A$   
 $CF = 2; FF = 2;$

---

---

---

---

---

---

---

---

### Power dissipated in diode

$$P_{Dreal} = \frac{1}{T} \int_0^T u_D(t) i_D(t) dt + \frac{1}{T} \int_0^T i_D^2(t) R_{Dseries} dt =$$

$$= U_D I_{DAV} + I_{DRMS}^2 R_{Dseries}$$

$$P_{Dreal} = 0.7V \cdot 1A + (3A)^2 \cdot 0.1\Omega =$$

$$= 0.7W + 0.9W$$

---

---

---

---

---

---

---

---

### Form Factor

$I_{DRMS}/I_{DAV} = FF$

n - liczba faz (1,2,3,6)

---

---

---

---

---

---

---

---

Rectifier comparison			
	Half-wave	Center-tap	Bridge
<b>C</b> To reach proper $U_{rip}$	$C \approx \frac{U_{OUT_{max}}}{U_{rip}} \cdot \frac{1}{fR_0}$	1/2(..)	1/2(..)
Maximum and RMS (diode current)	high	meadium	meadium
Diode revers voltage	$2E_{max}$	1(..)	1/2(..)
Current Harmonics	All Including DC ???	odd	odd

---

---

---

---

---

---

---

---

---

---

### Crest Factor & Waveform Factor

$CF = \frac{I_{MAX}}{I_{RMS}}$

Crest Factor - współczynnik szczytu  
For sin wave = 1,41 =  $\sqrt{2}$

$FF = \frac{I_{RMS}}{|I|_{AV}}$

Waveform Factor - współczynnik kształtu  
For sine wave = 1,11 =  $\pi/\sqrt{2}$

---

---

---

---

---

---

---

---

---

---

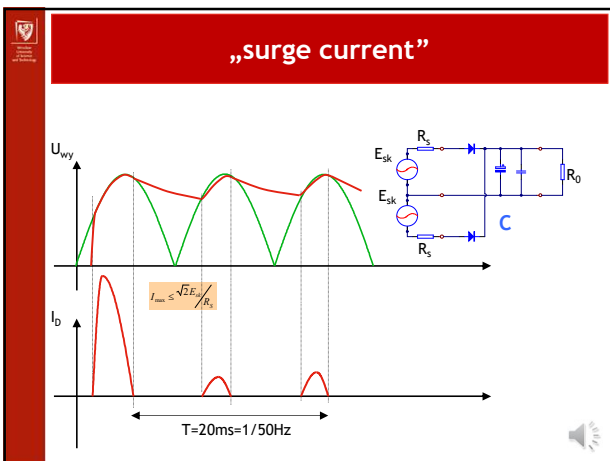

---

---

---

---

---

---

---

---

---

---

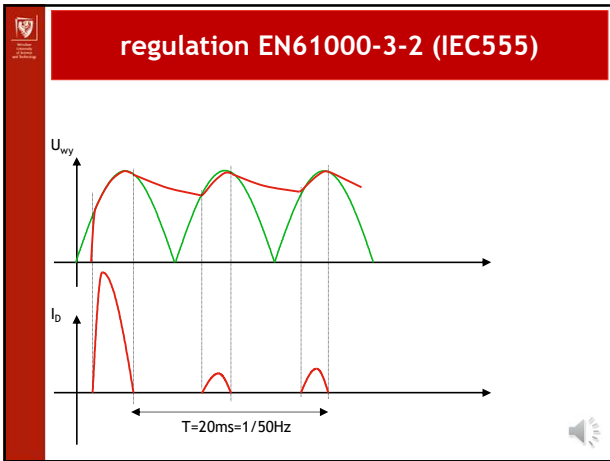

---

---

---

---

---

---

---

---

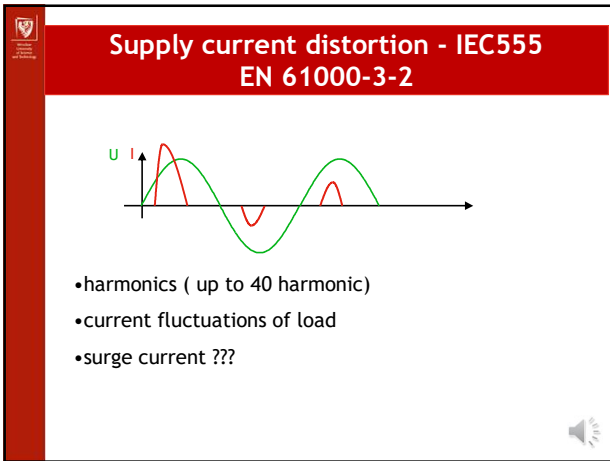

---

---

---

---

---

---

---

---

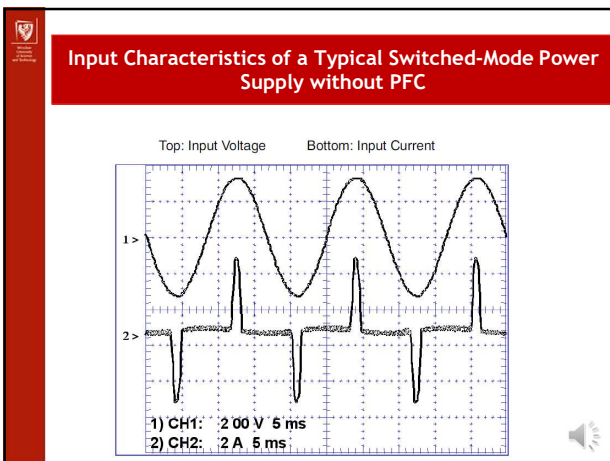

---

---

---

---

---

---

---

---

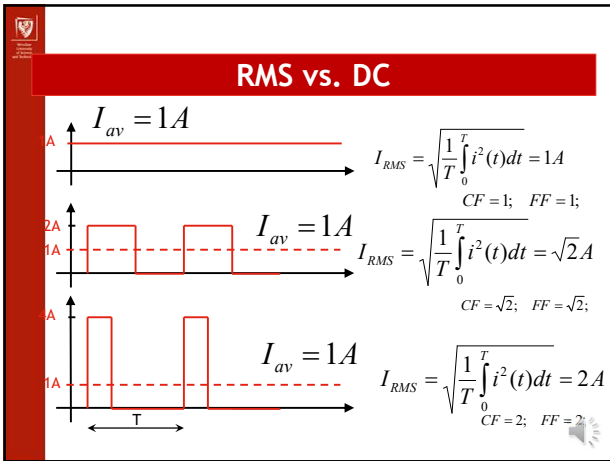

---

---

---

---

---

---

---

---

---

---

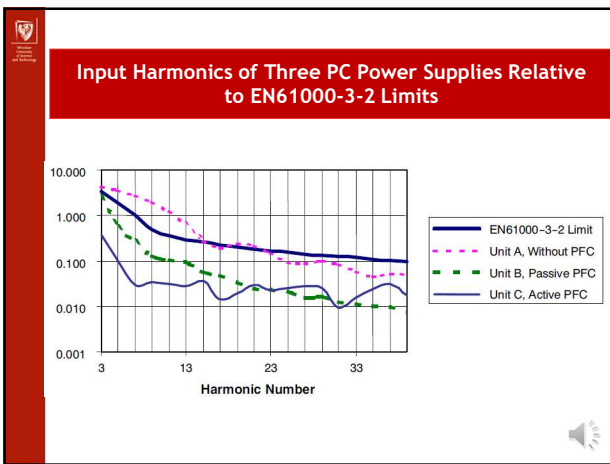

---

---

---

---

---

---

---

---

---

---

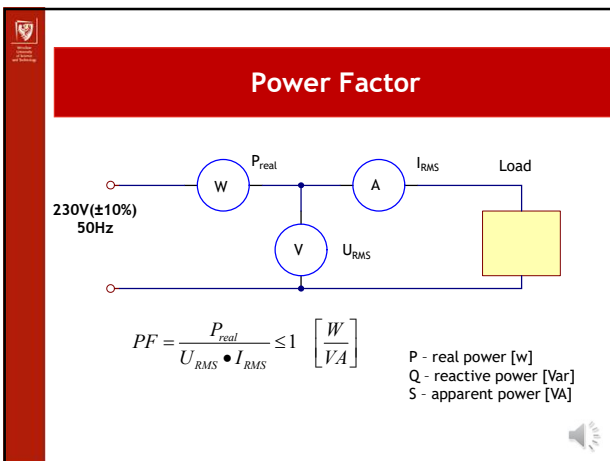

---

---

---

---

---

---

---

---

---

---

### Power triangle (no current harmonics case)

$$P = V_{RMS} I_{RMS} \cos \varphi$$

$S = V_{RMS} I_{RMS}$   
total apparent power

$Q = V_{RMS} I_{RMS} \sin \varphi$   
reactive or quadrature power

D95IN224A

---

---

---

---

---

---

---

---

### Power Factor $\eta = \cos \theta$

$U_{RMS} = 230V; U_{max} = 325V$

$I_{RMS} = \frac{1}{\eta} \frac{P}{U_{RMS}}$

**For this current PF=1**

$$I_{RMS} = \sqrt{\frac{1}{T} \int_0^T i^2 dt} \approx \sqrt{\frac{1}{20ms} (5A)^2 (2+2ms)} \approx 2,2A$$

$$P_{real} = \frac{1}{T} \int_0^T u(t)i(t) dt \approx 320V \cdot 5A \cdot \frac{4ms}{20ms} = 320W$$

$$PF = \frac{P_{real}}{U_{RMS} \cdot I_{RMS}} \approx \frac{320W}{230V \cdot 2,2A} \approx 0,63 \left[ \frac{W}{VA} \right]$$

---

---

---

---

---

---

---

---

### 0.8W

Waveform: V(D1-V1a) (R1)
Interval Start: 0s
Interval End: 100ms
Average: 590.34mW
Integral: 88.035mJ

---

---

---

---

---

---

---

---



**THD vs. PF ( $\cos \varphi_1 = 1$ )**

$$THD(\%) = 100 * \sqrt{\frac{1}{Kd^2} - 1}$$

$$Kd = \frac{1}{\sqrt{1 + \left(\frac{THD(\%)}{100}\right)^2}}$$

$$PF = \frac{1}{\sqrt{1 + \left(\frac{THD(\%)}{100}\right)^2}}$$

---

---

---

---

---

---

---

---

**THD vs. P.F.**

$$PF = \frac{\cos(\varphi_1)}{\sqrt{1 + \left(\frac{THD(\%)}{100}\right)^2}} = \cos(\theta) \cdot \cos(\varphi_1)$$

---

---

---

---

---

---

---

---

**Harmonic Content of the Current Waveform**

Harmonic Number	Percentage
1	100%
3	~92%
5	~82%
7	~68%
9	~52%
11	~38%
13	~25%
15	~18%
17	~12%
19	~8%
21	~5%

---

---

---

---

---

---

---

---

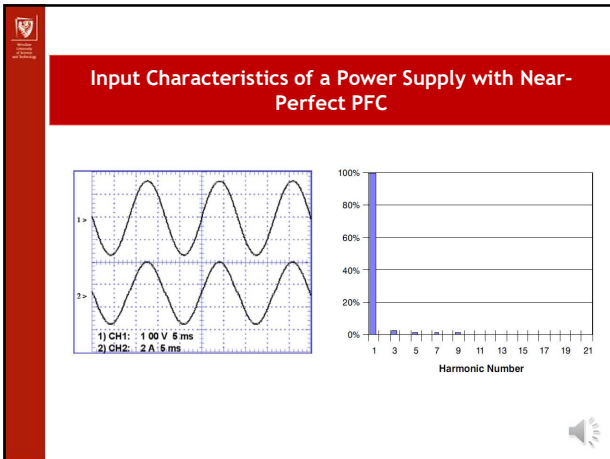

---

---

---

---

---

---

---

---

---

---

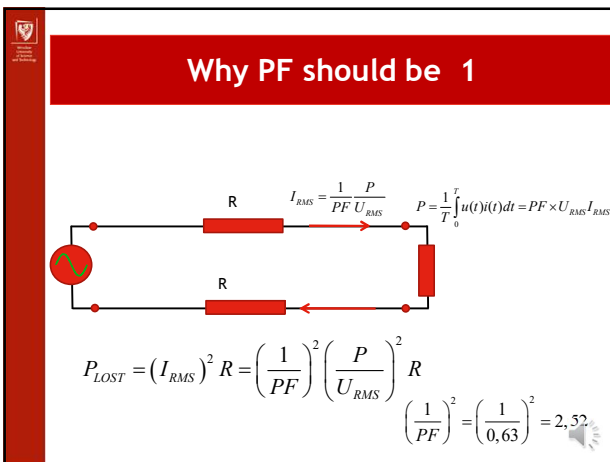

---

---

---

---

---

---

---

---

---

---

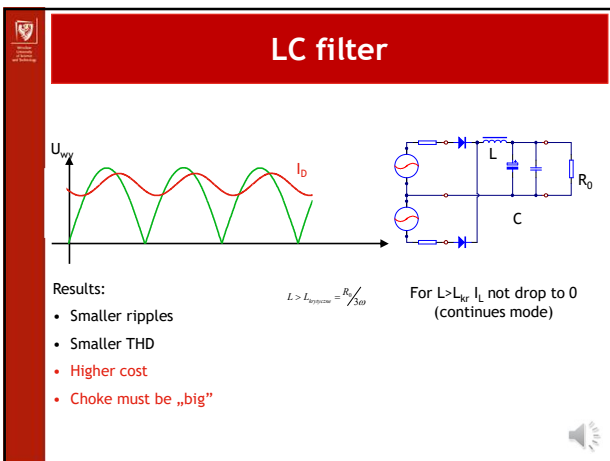

---

---

---

---

---

---

---

---

---

---

### Input Characteristics of PC Power Supplies with Different PFC Types (None, Passive, and Active)

Waveforms: 1. Input current with no PFC  
2. Input current with passive PFC  
3. Input current with active PFC  
4. Input voltage

CH1: 50 V, 2.0 ms  
CH2: 5 A, 2.5 ms  
CH3: 5 A, 2.5 ms  
CH4: 200 Volt, 2.5 ms

---

---

---

---

---

---

---

---

---

---

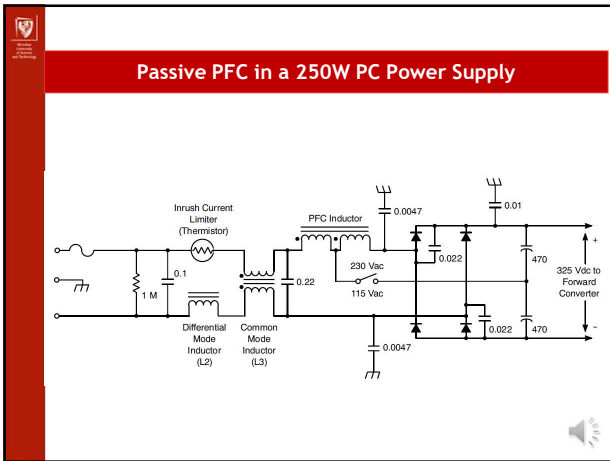

---

---

---

---

---

---

---

---

---

---

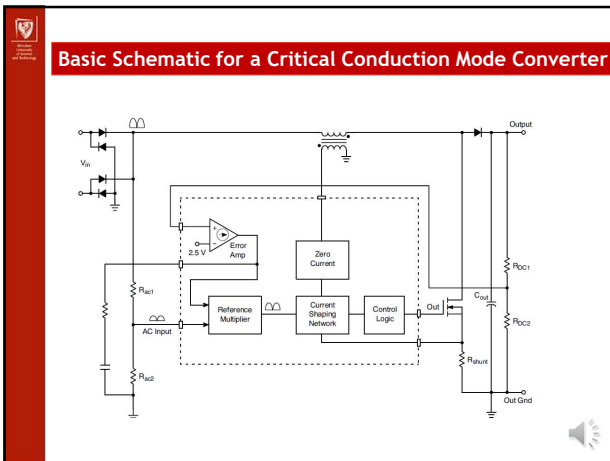

---

---

---

---

---

---

---

---

---

---

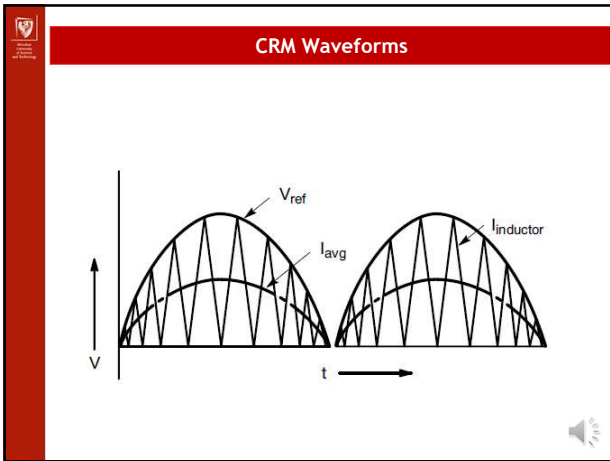

---

---

---

---

---

---

---

---

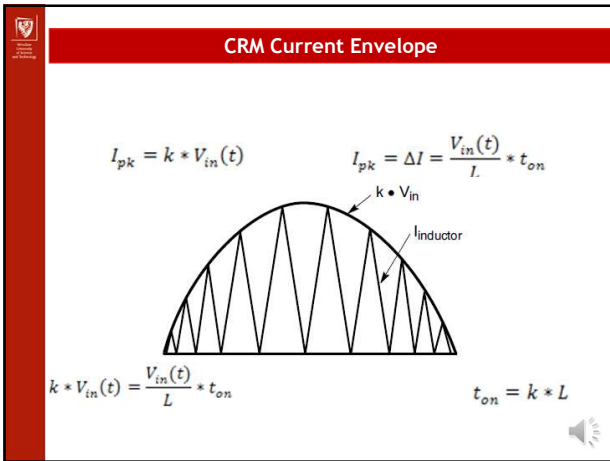

---

---

---

---

---

---

---

---

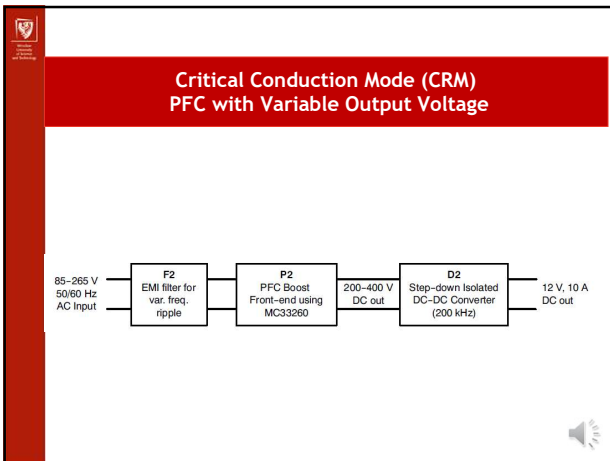

---

---

---

---

---

---

---

---

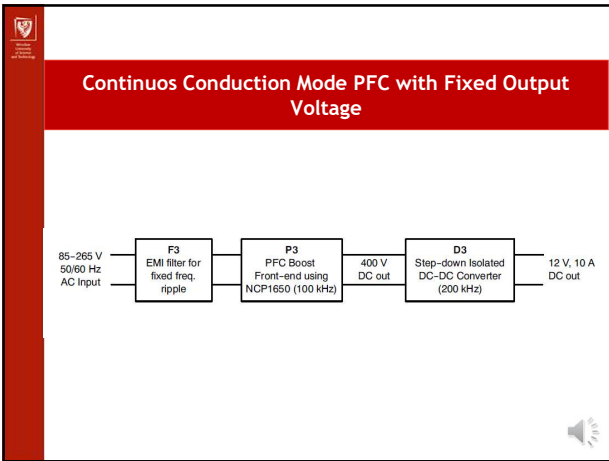

---

---

---

---

---

---

---

---

---

---

### References

Advertisement materials and application notes of  
„ON Semiconductor”

---

---

---

---

---

---

---

---

---

---

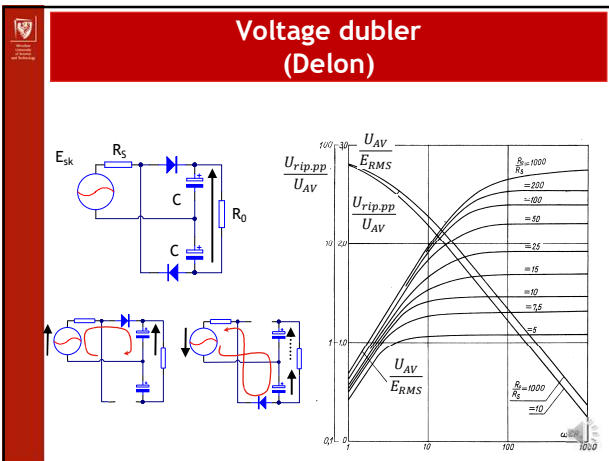

---

---

---

---

---

---

---

---

---

---

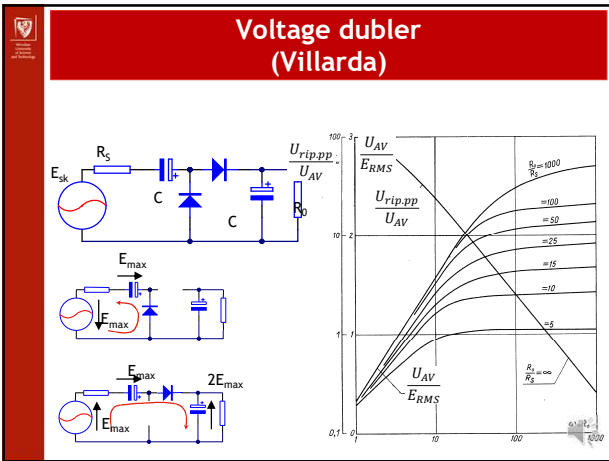

---

---

---

---

---

---

---

---

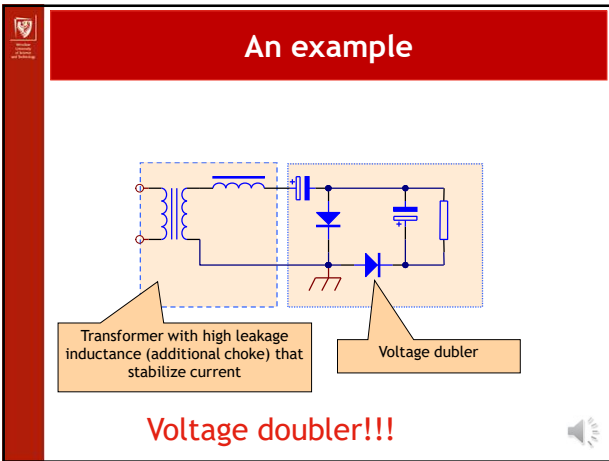

---

---

---

---

---

---

---

---

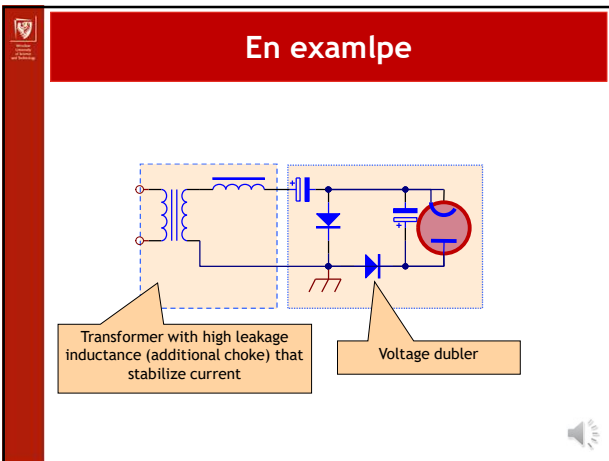

---

---

---

---

---

---

---

---

### An example

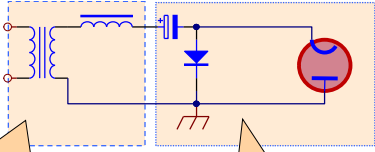

Microwave oven !!!

---

---

---

---

---

---

---

---

### Voltage multipliers

$$C \geq \frac{2n(n+2)}{fR_0}$$

$$U_{wy.sk} = n\sqrt{2}E_{sk} - U_i$$

$$U_i = \frac{U_{max}}{fC} \left( \frac{2}{3}n^3 + \frac{1}{2}n^2 - \frac{1}{6}n \right)$$

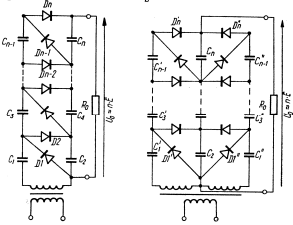

$$U_i = \frac{U_{max}}{fC} \left( \frac{1}{6}n^3 + \frac{1}{4}n^2 + \frac{1}{12}n \right)$$

---

---

---

---

---

---

---

---

### summary

- Transformer (parameters, types, equivalent schematic diagram)
- Types of rectifiers
- Resistive load rectifier (voltage, current waveforms)
- Rectifier with capacitive filter (voltage, current waveforms)
- Power Factor (definition, way of correction)

---

---

---

---

---

---

---

---



### Test questions

- Draw a simplified transformer diagram.
- Draw schematic diagram of rectifier (half wave, full wave, bridge).
- Draw wave shapes of voltage and currents in rectifier (3 types).
- 
- Power Factor definition?



---

---

---

---

---

---

---

---