



BJT amplifier CE, CC, CB



Wrocław University of Technology

Q- point

Assumption:
 $U_{BEQ} \approx 0,65V$
 β

Q-point:

$$\begin{cases} z \ I \Rightarrow U_B = I_{BQ}R_B + I_{CQ}R_C + U_{BEQ} \\ z \ II \Rightarrow E_C = I_{BQ}R_B + U_{BEQ} + I_{CQ}R_C \end{cases} \Rightarrow \begin{cases} I_{CQ} = \beta I_{BQ} = \beta \frac{U_B - U_{BEQ}}{R_B + (\beta + 1)R_C} \approx \frac{U_B - U_{BEQ}}{R_B/\beta + R_C} \\ U_{CEQ} = E_C - I_{CQ}(R_C + \frac{\beta + 1}{\beta}R_C) \approx E_C - I_{CQ}(\frac{\beta + 1}{\beta}R_C + R_C) \end{cases}$$

Wrocław University of Technology

Q - point vs. application

| Application | $I_C(Q)$ | $V_{CE}(Q)$ [V] |
|------------------------------------|-------------|-----------------|
| High input impedance amps | 0.1-10 [uA] | 0.7-5 |
| Low noise l.f. amps | 20-200 [uA] | 1-5 |
| Small signal l.f. & h.f. amps | 0.2-2 [mA] | 3-10 |
| Broadband h.f. amps; low noise h.f | 5-50 [mA] | 5-10 |
| Midium power l.f. amps | 0.1 -10 [A] | 5-15 |
| High power l.f. amps | 2-10 [A] | 20-200 |
| high power h.f. & special amps | 2-10 [A] | 20-1200 |

Wrocław University of Technology

CE amplifier

Wrocław University of Technology

Potentiometric biasing - an example

$$V_{BB} = V_{CC} \frac{R_{B2}}{R_{B1} + R_{B2}} = 4V$$

$$R_B = R_{B1} \parallel R_{B2} = 6.66k$$

$$V_{BE} = 0.65V; I_C \approx I_E; I_C = \beta_{DC} I_B$$

$$I_E \approx I_C = \frac{V_{BB} - V_{BE}}{R_E + R_B / \beta_{DC}} = 1.62mA$$

$$V_{CE} = V_{CC} - R_C I_C - R_E I_E \approx V_{CC} - (R_C + R_E) I_C = 5.5V$$

Wrocław University of Technology

AC & DC load line

$$V_{CE(ACcutoff)} = V_{CC} - V_E = 8.76V$$

$$I_{C(ACsat)} = \frac{V_{CC} - V_E}{R_C} = 4.38mA$$

Q-point is common for AC & DC (1.62mA; 5.5V)

Wrocław University of Technology

Ebers - Moll simplified model of BJT

$V_{BE} = 0.65V$

$I_C = \beta_{DC} I_B$

Wrocław University of Technology

CE amp AC model

Wrocław University of Technology

Diode - small signal dynamic resistance

$I_D = I_S \left(\exp\left(\frac{U_D}{\phi_T}\right) - 1 \right)$

$r_d = \left. \frac{dU_D}{dI_D} \right|_{U_D=U_Q} = \frac{\phi_T}{I_Q + I_S} \approx \frac{\phi_T}{I_Q}$

$r_d = \left. \frac{dU_D}{dI_D} \right|_{I_D=I_Q} \approx \frac{u}{i}$

$r_d = \frac{26mV}{1mA} = 26\Omega \quad \text{for } I_D = 1mA$

$I_Q = 1mA$

$I(t) = I_Q + i \sin(\omega t)$

$U(t) = U_Q + u \sin(\omega t)$

Wrocław University of Technology

Diode - small signal dynamic resistance

$$r_d = \left. \frac{dU_D}{dI_D} \right|_{I_D=I_Q} = \frac{\phi_T}{I_D + I_s} \approx \frac{\phi_T}{I_D}$$

$$r_d = \frac{26mV}{I_D} = \frac{26mV}{1mA} = 26\Omega \quad \text{for } I_D = 1mA; n = 1$$

$$r_d = \frac{26mV}{0.1mA} = 260\Omega \quad \text{for } I_D = 100\mu A; n = 1$$

$$r_d = \frac{26mV}{10\mu A} = 2.6k\Omega \quad \text{for } I_D = 10\mu A; n = 1$$

HINT:
The linear model is satisfactory for amplitudes up to 25mV

Wrocław University of Technology

Diode - small signal dynamic resistance

$$r_{be} = \frac{dV}{dI} \approx \frac{u}{i} \approx \frac{\phi_T}{I_B}$$

Wrocław University of Technology

CE amp model

Wrocław University of Technology

CE BJT amp

$$r_{be} = \frac{dV}{dI} \approx \frac{u}{i} \approx \frac{\varphi_T}{I_B}$$

Wrocław University of Technology

Early voltage; establishing of r_{ce}

$$r_{ce} = \frac{dV_{CE}}{dI_C} \approx \frac{u}{i} \approx \frac{V_{CEQ} + V_A}{I_{CQ}}$$

Wrocław University of Technology

CE amp BJT model

$$r_{ce} = \frac{dV_{CE}}{dI_C} \approx \frac{u}{i} \approx \frac{V_{CEQ} + V_A}{I_{CQ}}$$

Wrocław University of Technology

CE amp BJT model for midium frequencies

$$i_B = \frac{u_{be}}{r_{be}}$$

$$g_m = \frac{i_c}{u_{be}}$$

$$i_c = \beta_{AC} i_B$$

$$i_c = \beta_{AC} \frac{u_{be}}{r_{be}} = \frac{\beta_{AC}}{r_{be}} u_{be} = g_m u_{be} = g_m u_{in}$$

$$g_m = \frac{\beta_{AC}}{r_{be}} = \frac{I_{CQ}}{\varphi_T}$$

Wrocław University of Technology

CE amp BJT model for midium frequencies

$$u_{in} = e_G \frac{(r_{be} \parallel R_B)}{(r_{be} \parallel R_B) + R_G}$$

$$i_c = g_m u_{in}$$

$$u_{out} = -i_c (r_{ce} \parallel R_C \parallel R_L)$$

$$\frac{u_{out}}{e_G} = \frac{u_{in}}{e_G} \frac{i_c}{u_{in}} \frac{u_{out}}{i_c} = \underbrace{\frac{(r_{be} \parallel R_B)}{(r_{be} \parallel R_B) + R_G}}_{A_{i\text{effective}}} \underbrace{g_m (r_{ce} \parallel R_C \parallel R_L)}_{A_v}$$

Wrocław University of Technology

CE amp BJT model for medium frequencies

$$r_{in} = (r_{be} \parallel R_{B1} \parallel R_{B2})$$

$$r_{be} = \frac{\varphi_T}{I_{BQ}} = \frac{\varphi_T}{I_{CQ}} \beta_{AC}$$

$$g_m = \frac{\beta_{AC}}{r_{be}} = \frac{I_{CQ}}{\varphi_T}$$

$$\frac{u_{out}}{e_G} = \underbrace{-\frac{r_{in}}{r_{in} + R_G}}_A \underbrace{g_m (r_{ce} \parallel R_C \parallel R_L)}_{A_v}$$

$$A_{\text{effective}} = \frac{R_{LOAD}}{A_v}$$

Wrocław University of Technology

Watch please the video with example of CE amplifier analysis



Wrocław University of Technology

Summary of CE amp BJT medium frequencies

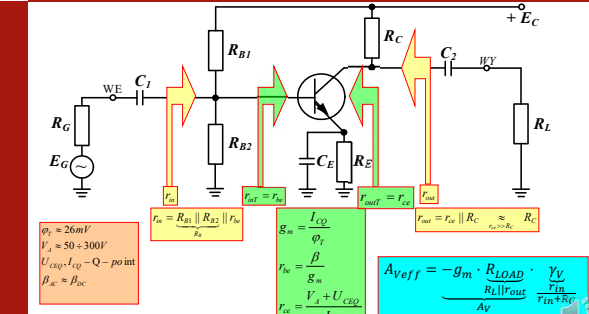

$\varphi_T \approx 26\text{ mV}$
 $V_T \approx 50 \div 300\text{ V}$
 $U_{CEQ}, I_{CEQ} - Q - \text{po int}$
 $\beta_{ac} = \beta_{dc}$

$r_{in} = R_{B1} \parallel R_{B2} \parallel r_{be}$
 $r_{be} = r_{be}$
 $r_{out} = r_{ce}$
 $r_{out} = r_{ce} \parallel R_C \approx R_C$ (if $r_{ce} \gg R_C$)

$g_m = \frac{I_{CEQ}}{\varphi_T}$
 $r_{ce} = \frac{\beta}{g_m}$
 $r_{ce} = \frac{V_T + U_{CEQ}}{I_{CEQ}}$

$A_{veff} = -g_m \cdot \frac{R_{LOAD}}{R_L \parallel r_{out}} \cdot \frac{U_{out}}{U_{in} \cdot R_C}$

Wrocław University of Technology

CE amp simple approach

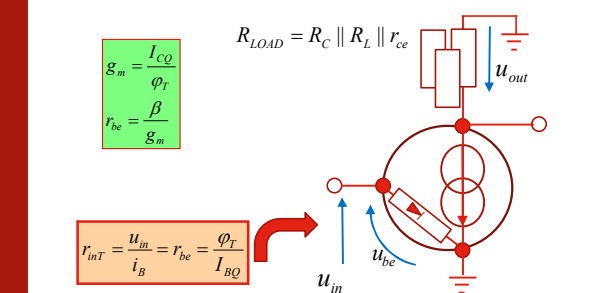

$g_m = \frac{I_{CEQ}}{\varphi_T}$
 $r_{be} = \frac{\beta}{g_m}$

$r_{inT} = \frac{u_{in}}{i_B} = r_{be} = \frac{\varphi_T}{I_{BQ}}$

$r_{in} = R_{B1} \parallel R_{B2} \parallel r_{inT}$

$R_{LOAD} = R_C \parallel R_L \parallel r_{ce}$

Wrocław University of Technology

CE amp simple approach

$R_{LOAD} = R_C \parallel R_L \parallel r_{ce}$

$$\begin{cases} i_C = g_m u_{be} \\ u_{out} = -i_C R_{LOAD} \end{cases}$$

↓

$$A_V = \frac{u_{out}}{u_{in}} = -g_m R_{LOAD}$$

$$g_m = \frac{I_{CQ}}{\varphi_T}$$

$$r_{be} = \frac{\beta}{g_m}$$

Wrocław University of Technology

CB CE CC

Wrocław University of Technology

CC amplifier

Wrocław University of Technology

CC - emitter follower

$$i_c = g_m u_{be}$$

$$\begin{cases} i_c = g_m u_{be} \\ u_{out} \approx i_c R_{LOAD} \\ u_{in} = u_{be} + u_{out} \end{cases}$$

$$A_v = \frac{u_{out}}{u_{in}} = \frac{R_{LOAD}}{R_{LOAD} + \frac{1}{g_m}} = \frac{R_{LOAD}}{R_{LOAD} + \frac{\varphi_T}{I_{CQ}}} \approx < 1$$

$$R_{LOAD} = R_E \parallel R_L \parallel r_{ce}$$

Wrocław University of Technology

CC - emitter follower

$$\begin{cases} u_{be} = i_B r_{be} = \frac{i_c}{\beta} r_{be} \\ u_E = i_E R_{LOAD} \approx i_c R_{LOAD} \\ u_{in} = u_{be} + u_E = i_B r_{be} + \beta i_B R_{LOAD} \end{cases}$$

$$r_{int} = \frac{u_{in}}{i_B} = r_{be} + \beta R_{LOAD}$$

$$R_{LOAD} = R_E \parallel R_L \parallel r_{ce}$$

Wrocław University of Technology

Wrocław University of Technology

AC emitter feedback

$$u_{in} = u_{be} + u_E = i_B r_{be} + i_E \beta R_E$$

$$r_{inT} = \frac{u_{in}}{i_B} = r_{be} + \beta R_E$$

Wrocław University of Technology

AC emitter feedback

$$R_{LOAD} = R_C \parallel R_L \parallel r_c$$

$$\begin{cases} i_C = g_m u_{be} \\ u_{in} = u_{be} + u_E \\ u_E = i_C R_E = \frac{R_E}{R_E + 1/g_m} u_{in} \\ u_{out} = -i_C R_{LOAD} = \frac{-R_{LOAD}}{R_E + 1/g_m} u_{in} \end{cases}$$

$$A_V = \frac{u_{out}}{u_{in}} = -\frac{R_{LOAD}}{R_E + 1/g_m} \approx -\frac{R_{LOAD}}{R_E}$$

Wrocław University of Technology

2 outputs emitter feedback amp

$$A_{vC} = \frac{u_C}{u_{in}} = -\frac{R_C}{R_E + 1/g_m} \approx -\frac{R_C}{R_E}$$

$$A_{vE} = \frac{u_E}{u_{in}} = \frac{R_E}{R_E + 1/g_m} \approx 1$$

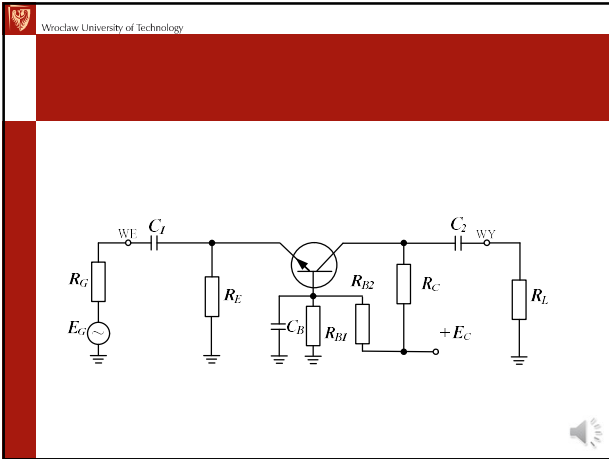

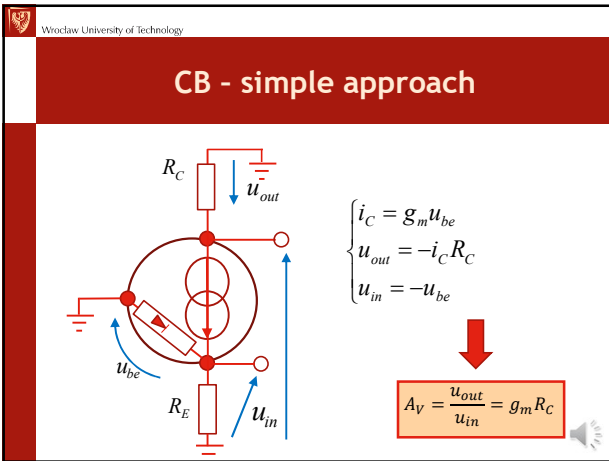

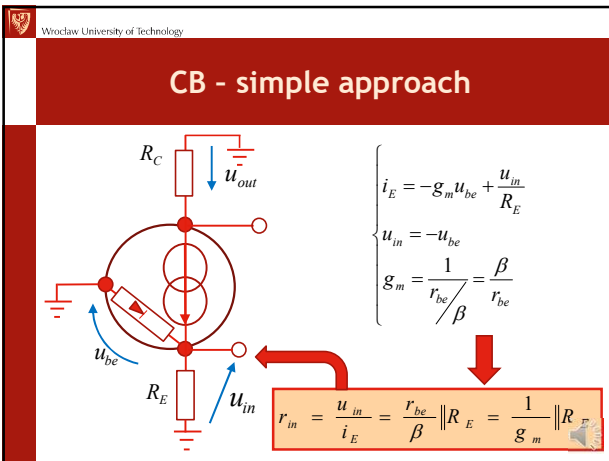

Wrocław University of Technology

y_{xx} and h_{xx} parameters

$$\begin{bmatrix} I_1 \\ I_2 \end{bmatrix} = \begin{bmatrix} y_{11} & y_{12} \\ y_{21} & y_{22} \end{bmatrix} \begin{bmatrix} V_1 \\ V_2 \end{bmatrix}$$

$$r_{be} = h_{11} = h_{ie} = \frac{1}{y_{11}}$$

$$g_m = y_{21}$$

$$\begin{bmatrix} V_1 \\ V_2 \end{bmatrix} = \begin{bmatrix} h_{11} & h_{12} \\ h_{21} & h_{22} \end{bmatrix} \begin{bmatrix} I_1 \\ I_2 \end{bmatrix}$$

$$\beta = h_{21} = h_{fe} = \frac{y_{21}}{y_{11}}$$

$$r_{ce} = \frac{1}{h_{22}} = \frac{1}{y_{22}}$$

Wrocław University of Technology

CE-CC-CB comparison

$R_B = R_{B1} \parallel R_{B2} \quad r_{be} / \beta = 1 / g_m$

| Parameter | configuration | | |
|---|--|--|--|
| | CE | CC | CB |
| $A_v = \frac{u_{be}}{u_L}$ | $-\beta \frac{R_C \parallel R_L \parallel r_{ce}}{r_{be}}$ | $\frac{R_E \parallel R_L \parallel r_{ce}}{R_E \parallel R_L \parallel r_{ce} + r_{be} / \beta}$ | $-\beta \frac{R_C \parallel R_L \parallel r_{ce}}{r_{be}}$ |
| $A_i = \frac{i_b}{i_L}$ | $\frac{-R_C \parallel r_{ce}}{R_C \parallel r_{ce} + R_L} \beta$ | $\frac{R_E}{R_E + R_L} \beta$ | $\frac{-R_C \parallel r_{ce}}{R_C \parallel r_{ce} + R_L}$ |
| $r_{in} = \frac{u_{be}}{i_{b(e)}}$ | $R_B \parallel r_{be}$ | $(\beta(R_E \parallel R_L) + r_{be}) \parallel R_B$ | $\left(\frac{r_{be}}{\beta}\right) \parallel R_E$ |
| $r_{out} = \frac{u_{out}}{i_{c(e)}}$ <small>(e) - for CB</small> | $R_C \parallel r_{ce}$ | $\left(\frac{(R_B \parallel R_G) + r_{be}}{\beta}\right) \parallel R_E$ | $R_C \parallel r_{ce}$ |

Wrocław University of Technology

CE-CC-CB general comparison

| Parameter | configuration | | |
|---|---|---|---|
| | CE | CC | CB |
| $A_v = \frac{u_{be}}{u_L}$ | High <small>(10-200)</small> | <1 | High <small>(10-200)</small> |
| $A_i = \frac{i_b}{i_L}$ | High <small>(10-200)</small> | High <small>(10-200)</small> | <1 |
| $r_{in} = \frac{u_{be}}{i_{b(e)}}$ | Medium <small>(0.5k-5k)</small> | High <small>(10k-1M)</small> | Low <small>(10Ω-500Ω)</small> |
| $r_{out} = \frac{u_{out}}{i_{c(e)}}$ <small>(e) - for CB</small> | Medium <small>(0.5k-5k)</small> | Low <small>(10Ω-500Ω)</small> | Medium <small>(0.5k-5k)</small> |

Wrocław University of Technology

Summary

- AC vs. DC load line
- Ebers - Moll BJT model
- linear transistor model
- voltage gain, effective voltage gain
- CE, CC, CB amps parameters



Wrocław University of Technology

Problems

- Estimate voltage gain and effective voltage gain for given diagram of BJT CE amplifier (known parameters: $R_g, R_{B1}, R_{B2}, R_C, R_L, \beta, \varphi_T, I_{CQ}, U_{CEQ}$).
- What is the „emitter follower” and what characteristic parameters it has ?
- Compare BJT amplifier in CE, CB, CC configurations.

