



Wrocław University of Science and Technology



Power factor correction



References

Advertisement materials and application notes of „ON Semiconductor”



Full wave rectifier

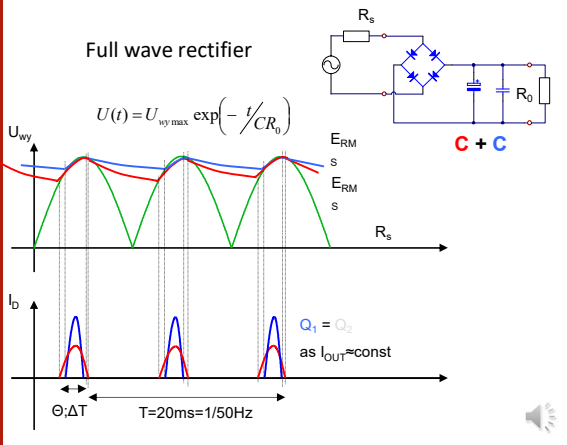

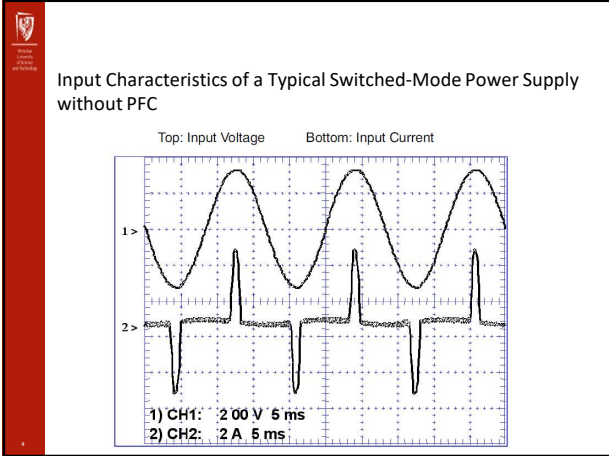

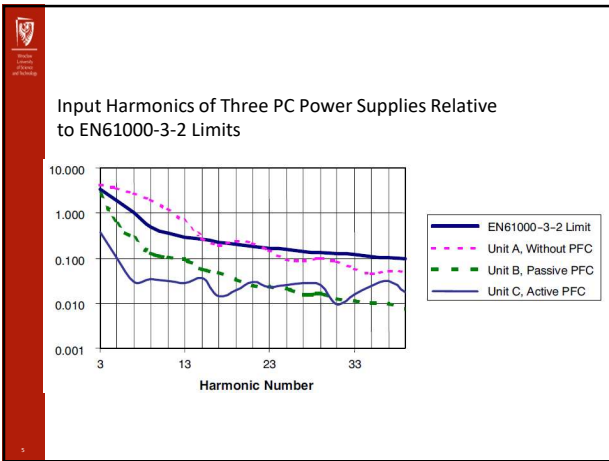

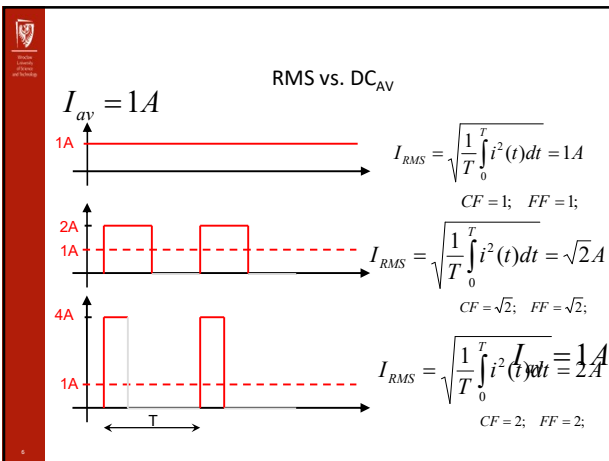

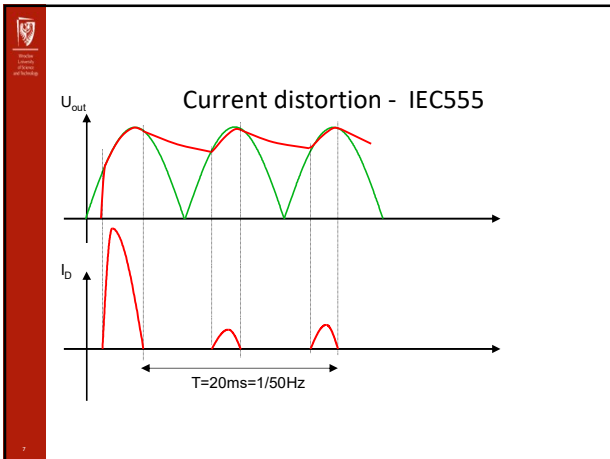

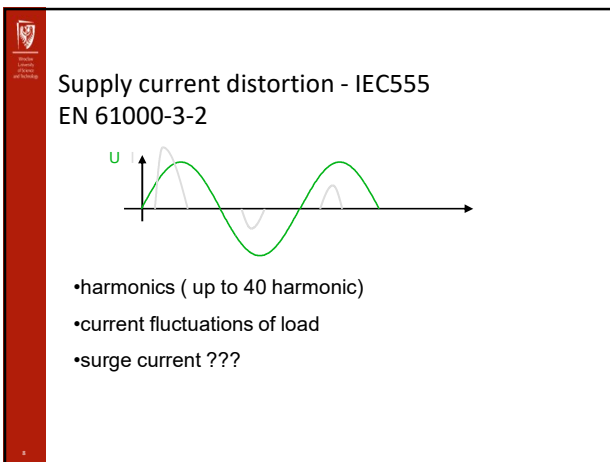

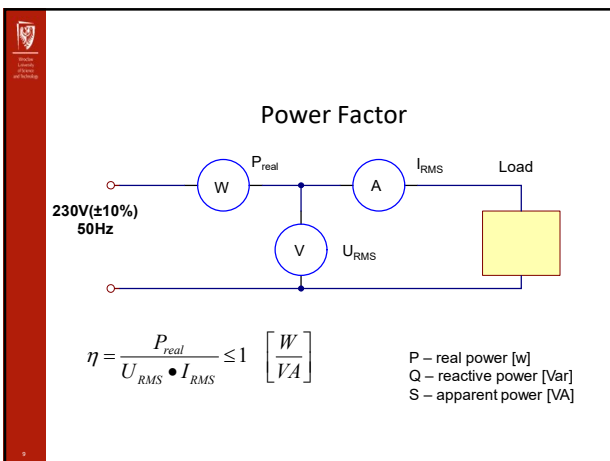

Power triangle
(no current harmonics case)

$$P = V_{RMS} I_{RMS} \cos \varphi$$

$S = V_{RMS} I_{RMS}$
total apparent power

$Q = V_{RMS} I_{RMS} \sin \varphi$
reactive or quadrature power

D95IN224A

Power Factor $\eta = \cos \theta$

$U_{RMS} = 230V; U_{max} = 325V$

325V
5A

20ms

2ms

I_{RMS}

P

For this current $\eta = 1$

$$|I_{AV}| = \frac{1}{T} \int_0^T |i| dt \approx \frac{1}{20ms} (5A) (2 + 2ms) \approx 1A$$

$$I_{RMS} = \sqrt{\frac{1}{T} \int_0^T i^2 dt} \approx \sqrt{\frac{1}{20ms} (5A)^2 (2 + 2ms)} \approx 2,2A$$

$$P_{real} = \frac{1}{T} \int_0^T u(t)i(t) dt \approx 320V \cdot 5A \cdot \frac{4ms}{20ms} = 320W$$

$$\eta = \frac{P_{real}}{U_{RMS} \cdot I_{RMS}} \approx \frac{320W}{230V \cdot 2,2A} \approx 0,63 \left[\frac{W}{VA} \right]$$

Power triangle
(no current harmonics case)

In-phase

$$P = \text{Real Power} = V_{RMS} \cdot I_{RMS} \cos \varphi$$

$S_1 = \text{Apparent fundamental power} = V_{RMS} \cdot I_{RMS}$

$S = \text{Total Apparent Power} = V_{RMS} \cdot I_{RMS} = \text{Total Real}$

$Q = \text{Reactive Power} = V_{RMS} \cdot I_{RMS} \sin \varphi$
quadrature

$D = \text{Distortion Power} = V_{RMS} \sqrt{\sum_{n=2}^{\infty} I_{n,RMS}^2}$

D95IN225A



Total P.F. = $\eta = \cos \varphi_1 \cos \theta$

φ_1 is the "conventional" displacement angle (phase lag) between the in-phase fundamental I and V
 θ is the distortion angle linked to the harmonic content of the current.

Both of reactive (Q) and distortion (D) powers produce extra RMS currents, giving extra losses so that then the mains supply network efficiency is decreased.

Improving P.F. means to improve both of factors i.e.:

$\varphi_1 \rightarrow 0 \quad \cos \varphi_1 \rightarrow 1 =$ reduce phase lag between I and V
 $\theta \rightarrow 0 \quad \cos \theta \rightarrow 1 =$ reduce harmonic content of I

13



THD(i) vs. P.F. ($\cos \varphi_1 = 1$) .

$$PF = \frac{1}{\sqrt{1 + \left(\frac{THD(\%)}{100}\right)^2}}$$

14



THD vs. P.F.

$$P.F. = \frac{\cos(\varphi_1)}{\sqrt{1 + \left(\frac{THD(\%)}{100}\right)^2}} = \cos(\theta) \cdot \cos(\varphi_1)$$

15

Why PF=η should be 1

$$I_{RMS} = \frac{1}{\eta} \frac{P}{U_{RMS}}$$

$$P = \frac{1}{T} \int_0^T u(t)i(t)dt = \eta U_{RMS} I_{RMS}$$

$$P_{LOST} = (I_{RMS})^2 R = \left(\frac{1}{\eta}\right)^2 \left(\frac{P}{U_{RMS}}\right)^2 R$$

$$\left(\frac{1}{\eta}\right)^2 = \left(\frac{1}{0,63}\right)^2 = 2,52$$

$$P_{LOST} = (I_{RMS})^2 R = \left(\frac{1}{\eta}\right)^2 \left(\frac{P_{load}}{U_{RMS}}\right)^2 R$$

0.8W

Waveform: V(D1-VIa) (R1)
Interval Start: 0s
Interval End: 100ms
Average: 960.34mW
Integral: 86.034mJ

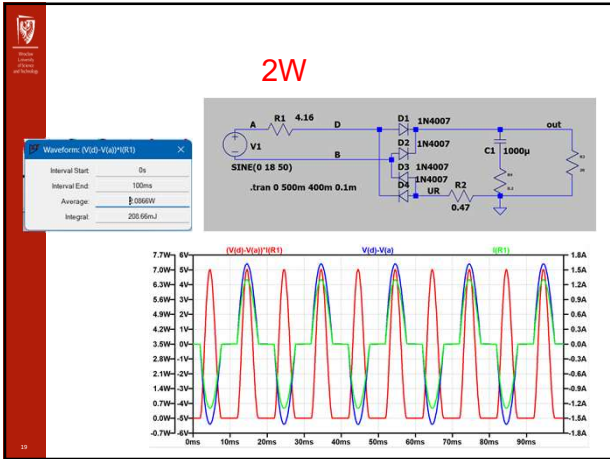

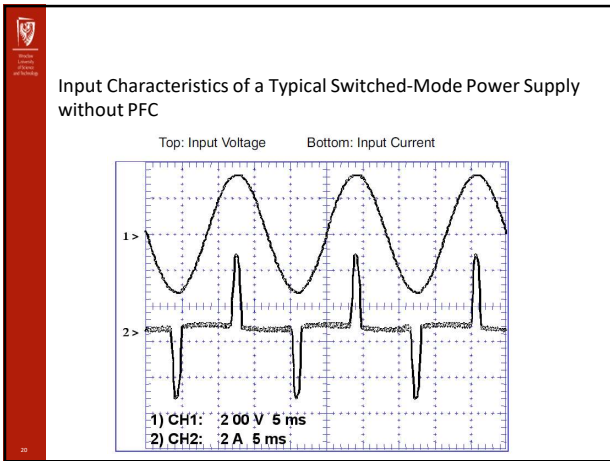

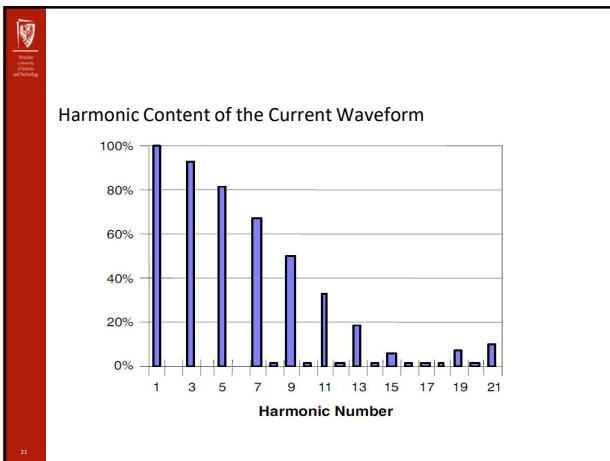

Input Characteristics of a Power Supply with Near-Perfect PFC

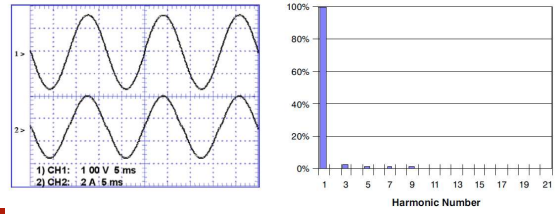

Input Characteristics of PC Power Supplies with Different PFC Types (None, Passive, and Active)

- Waveforms:
1. Input current with no PFC
 2. Input current with passive PFC
 3. Input current with active PFC
 4. Input voltage

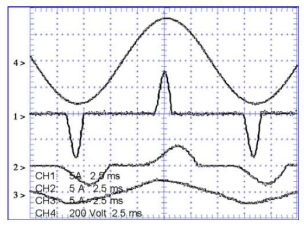

Input Harmonics of Three PC Power Supplies Relative to EN61000-3-2 Limits

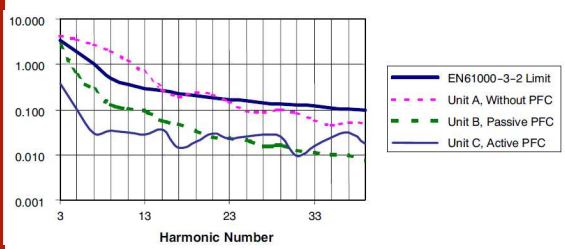

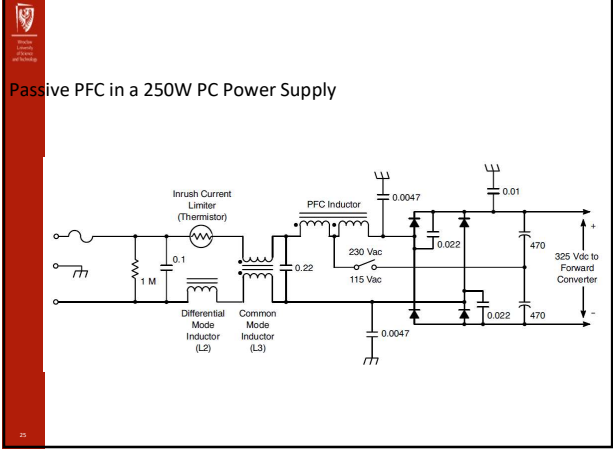

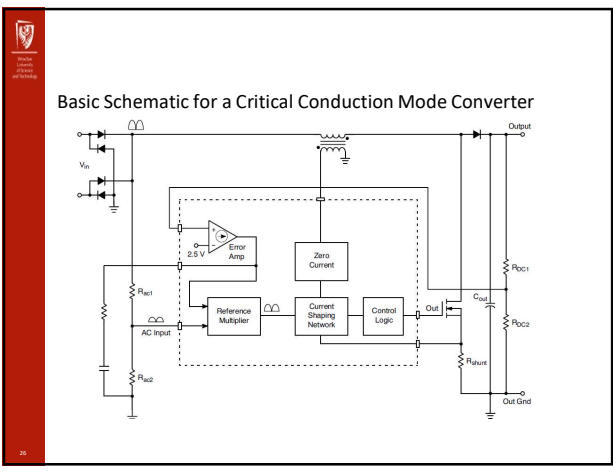

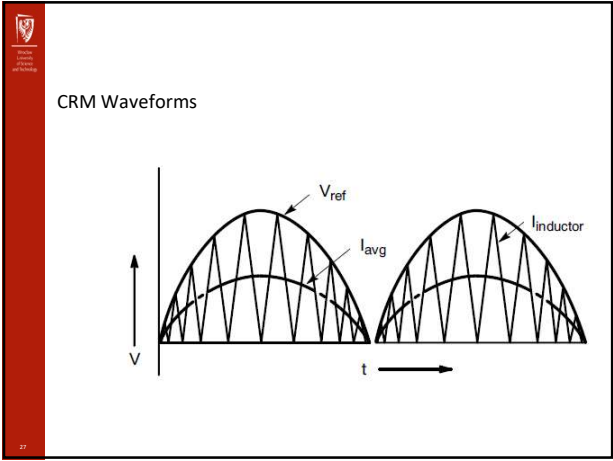

CRM Current Envelope

$$I_{pk} = k * V_{in}(t)$$

$$I_{pk} = \Delta I = \frac{V_{in}(t)}{L} * t_{on}$$

$$k * V_{in}(t) = \frac{V_{in}(t)}{L} * t_{on}$$

$$t_{on} = k * L$$

Simplified Schematic of CRM Controller without Multiplier

Follower Boost

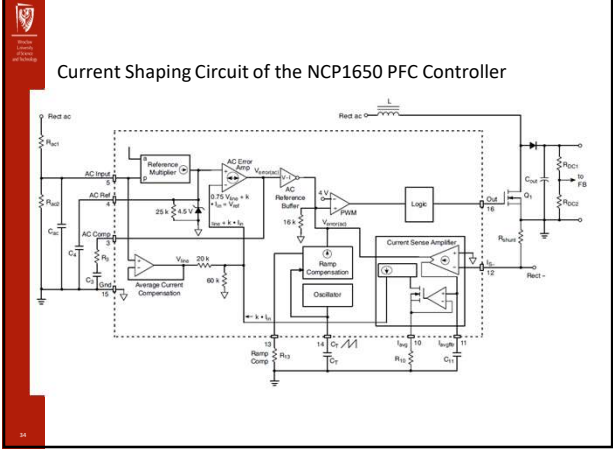

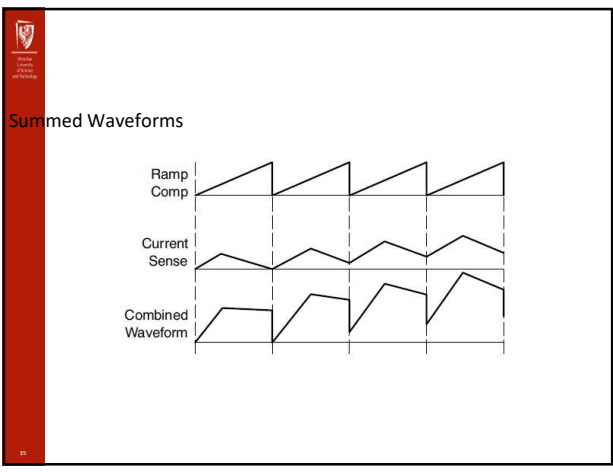

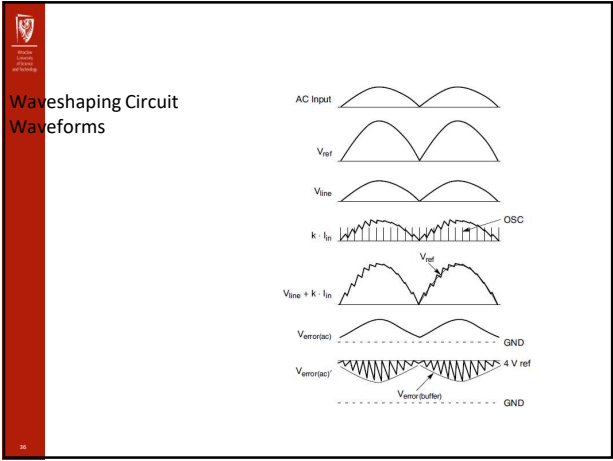

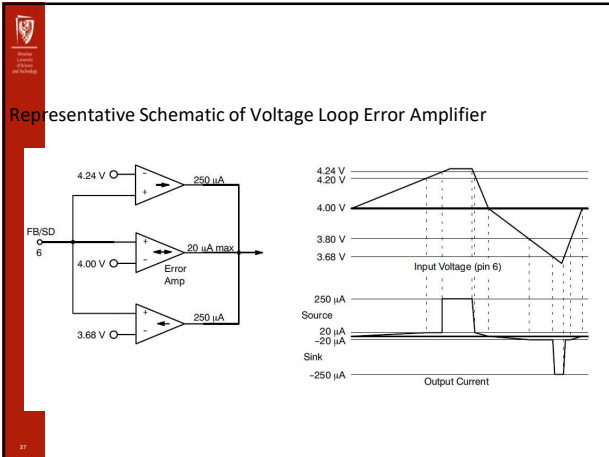

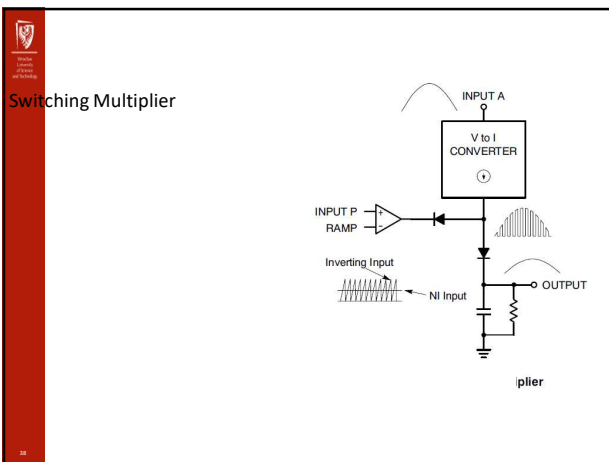

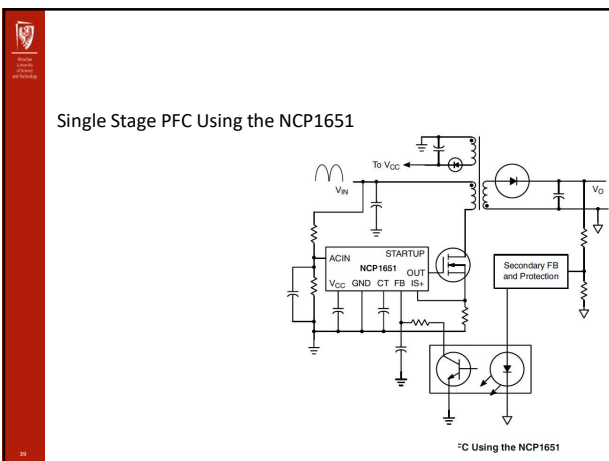

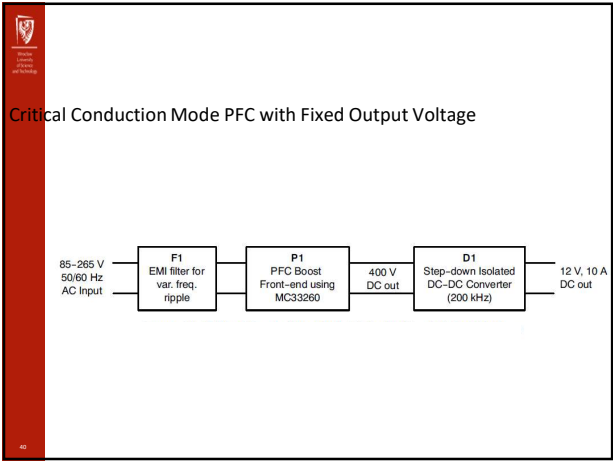

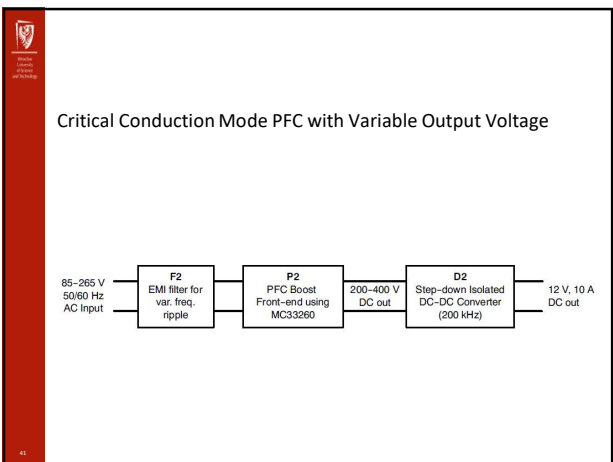

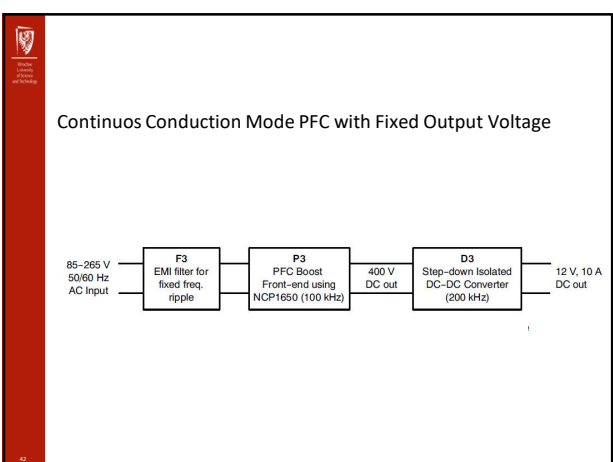

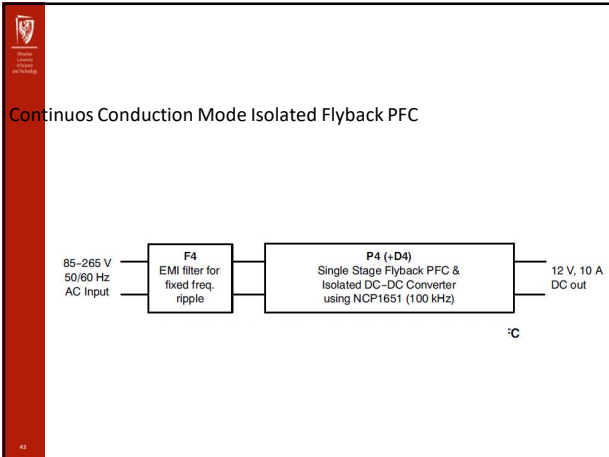

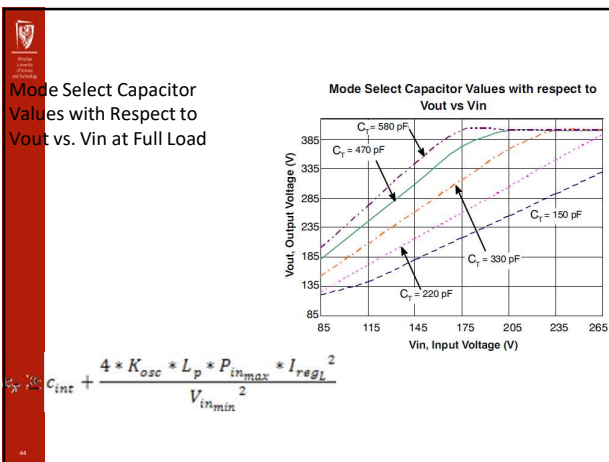

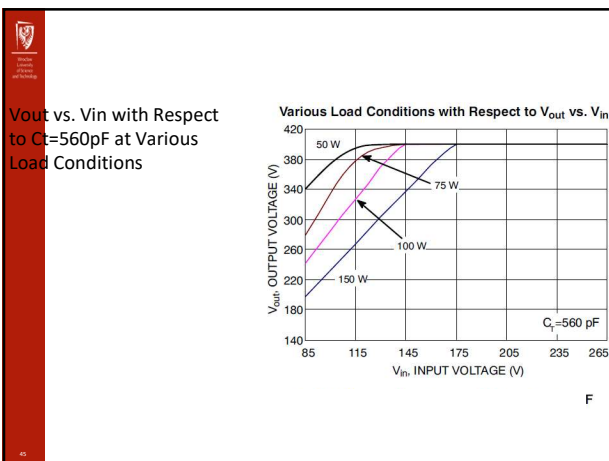



Inductor (Lp)

$$I_{in_pk} = \frac{\sqrt{2} \cdot P_{out}}{\eta \cdot V_{in\ min}}$$

$$I_{coil_pk} = 2 \cdot I_{in_pk}$$

$$L_p = \frac{2 \cdot T_{total} \cdot \left(\frac{V_{out}}{\sqrt{2}} \cdot V_{in\ min}\right) \cdot V_{in\ min}}{V_{out} \cdot I_{coil_pk}} = 607 \mu H \text{ for the traditional boost}$$

$$L_p = \frac{2 \cdot T_{total} \cdot \left(\frac{V_{out}}{\sqrt{2}} \cdot V_{in\ min}\right) \cdot V_{in\ min}}{V_{out} \cdot I_{coil_pk}} = 200 \mu H \text{ for the follower boost}$$

42



Power Switch

$$I_Q = \sqrt{\frac{1}{6} \cdot \frac{4\sqrt{2} \cdot V_{in\ min}}{9 \cdot \pi \cdot V_{out}} \cdot I_{coil_pk}}$$

47



Output Capacitor

Energy = Power x Time
 where power = 150 W (output power)
 and time = 20 ms (hold - up time)

$$\Delta U = U_1 - U_2 = \frac{1}{2} C_{out} (V_{out}^2 - V_{out\ min}^2)$$

$$C_{out} = \frac{2 \cdot \Delta U}{V_{out}^2 - V_{out\ min}^2} = \frac{2 \cdot 3}{400^2 - 280^2} = 74 \mu F \text{ for the Traditional Boost}$$

$$C_{out} = \frac{2 \cdot \Delta U}{V_{out}^2 - V_{out\ min}^2} = \frac{2 \cdot 3}{200^2 - 150^2} = 342 \mu F \text{ for the Follower Boost}$$

42



Current Sense

Dissipation capability for RCS:

$$P_{CS} = \frac{1}{6} \cdot R_{CS} \cdot I_{coil_pk}^2$$

Overcurrent protection resistor:

$$R_{OCP} = \frac{R_{CS} \cdot I_{coil_pk}}{I_{OCP}}$$

12



MC33260 Traditional and Follower Boost Schematic

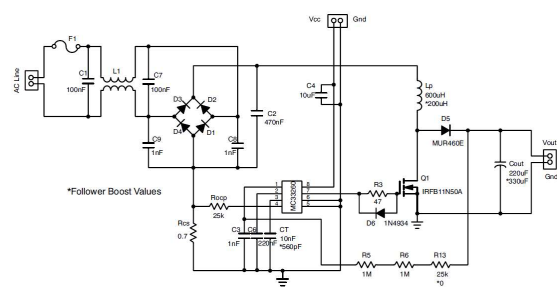

13



Design Table – Traditional and Follower Boost

Mode Select	Traditional Boost	Follower Boost
P _O (W)	150	150
L _p (μH)	607	200
C _O (μF)	220	330
R _{CS} (Ω)	0.7	0.7
R _{OCP} (kΩ)	20	20
C _T (pF)	10000	560

14



Power Switch

$$V_{DS} = \sqrt{2} \cdot V_{in\ max} + \frac{N_p}{N_s} \cdot V_{out} + I_p \cdot \sqrt{\frac{L_p(\text{leakage})}{C_p + C_{oss}}}$$

$$I_{pk} = \frac{\sqrt{2} \cdot P_{in} \cdot T}{V_{in\ min} \cdot t_{on}} + \frac{2 \cdot \sqrt{2} \cdot V_{in\ min} \cdot t_{on}}{L_p}$$

22



Primary and Secondary Currents of the Flyback Transformer

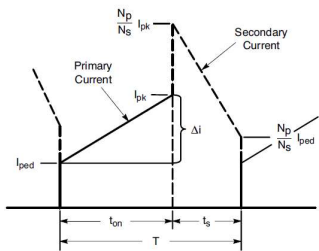

Figure 39. Primary and Secondary Currents of the Flyback Transformer

23



Output Rectifier

$$V_R \geq V_{out} + \sqrt{2} \cdot V_{in\ max} \cdot \frac{N_s}{N_p}$$

$$P_d = V_F \cdot I_F \cdot (1-D) \text{ with } I_F = \frac{(I_{pk} + I_{ped})}{2} \cdot \frac{N_p}{N_s}$$

24

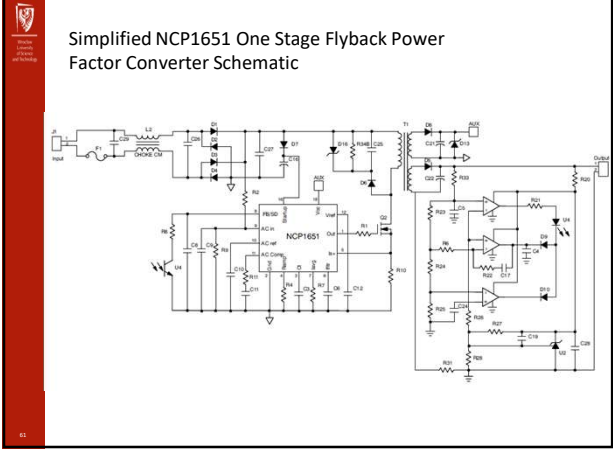

NCP1651 PFC Circuit Results

Vin (Vac)	85	115	230	265
Pin (W)	153.8	146	140.1	140.3
Iline(rms)	1.80	1.27	0.63	0.56
Vout (V)	11.72	11.78	11.77	11.78
Iout (A)	10	10	10	10
Efficiency (%)	76.2	80.7	84.0	84.0
PF (%)	99.79	99.86	96.70	93.87
THD (%)	4.76	4.29	6.4	7.9

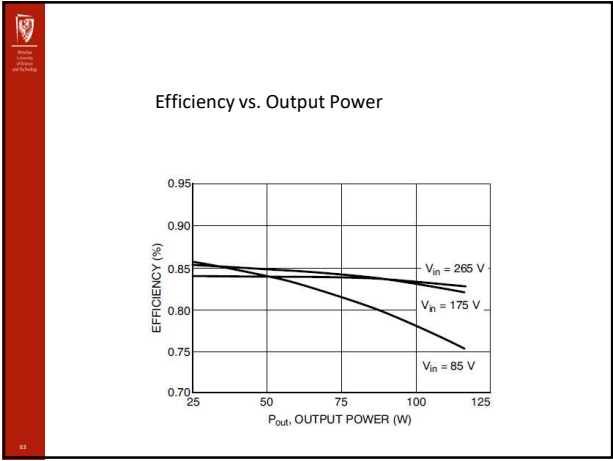

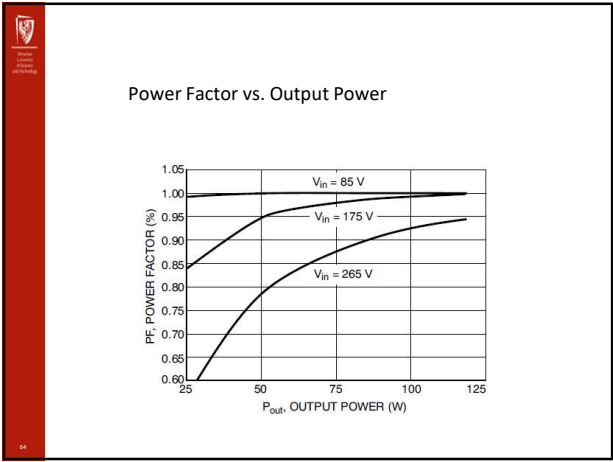

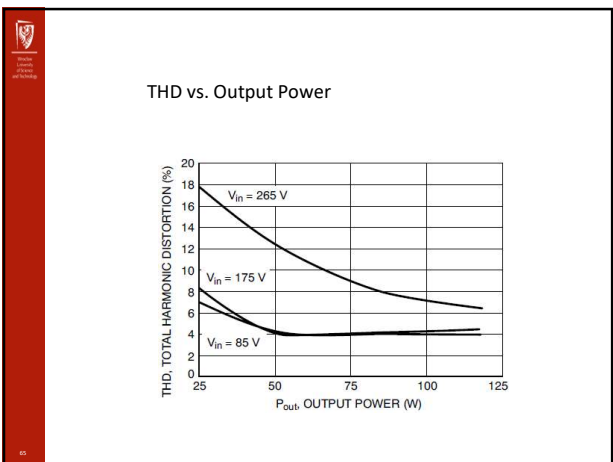

- Summary**
- PF definition
 - PF vs. THD
 - PFC methods
