

Wrocław University of Science and Technology

Electrostatic Discharge

IEP

Speaker icon

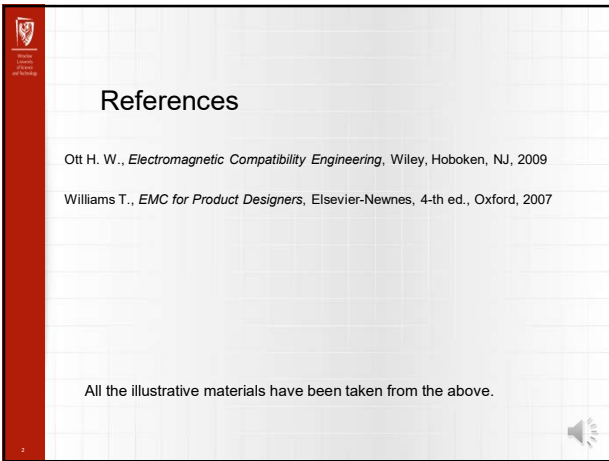

References

Ott H. W., *Electromagnetic Compatibility Engineering*, Wiley, Hoboken, NJ, 2009

Williams T., *EMC for Product Designers*, Elsevier-Newnes, 4-th ed., Oxford, 2007

All the illustrative materials have been taken from the above.

2

Speaker icon

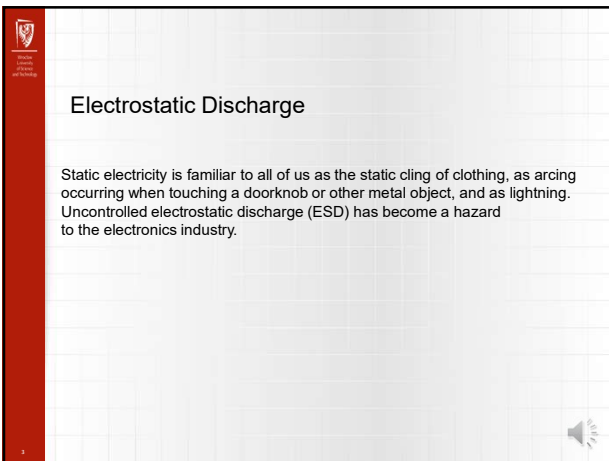

Electrostatic Discharge

Static electricity is familiar to all of us as the static cling of clothing, as arcing occurring when touching a doorknob or other metal object, and as lightning. Uncontrolled electrostatic discharge (ESD) has become a hazard to the electronics industry.

3

Speaker icon

STATIC GENERATION

Static electricity can be created in many different ways, but the most common is by contact and subsequent separation of materials.

Table below is a typical triboelectric series.

TABLE 15-1. Triboelectric Series

POSITIVE	
1. Air	18. Hard rubber
2. Human skin	19. Mylar [®]
3. Asbestos	20. Epoxy glass
4. Glass	21. Nickel, copper
5. Mica	22. Brass, silver
6. Human hair	23. Gold, platinum
7. Nylon	24. Polystyrene foam
8. Wool	25. Acrylic
9. Fur	26. Polyester
10. Lead	27. Celluloid
11. Silk	28. Orlon
12. Aluminum	29. Polyurethane foam
13. Paper	30. Polyethylene
14. Cotton	31. Polypropylene
15. Wood	32. PVC (vinyl)
16. Steel	33. Silicon
17. Amber	34. Teflon [®]
	NEGATIVE

STATIC GENERATION

When two materials are in contact, electrons will transfer from the material higher on the list to the material lower on the list.

$$V = \frac{Q}{C}$$

 STATIC GENERATION

Means of Static Generation	Electrostatic Voltage	
	10% to 20% Relative Humidity	65% to 90% Relative Humidity
Walking across carpet	35,000	1500
Walking on vinyl floor	12,000	250
Worker moving at bench	6000	100
Opening a vinyl envelope	7000	600
Picking up common polyethylene bag	20,000	1200
Sitting on chair padded with polyurethane foam	18,000	1500



 STATIC GENERATION

Static electricity is a surface phenomenon.



 STATIC GENERATION

Electrostatic discharge is a three-step process:

1. A charge is generated on an insulator.
2. This charge is transferred to a conductor by contact or induction.
3. The charged conductor comes near a metal object and a discharge occurs.



STATIC GENERATION
Inductive Charging

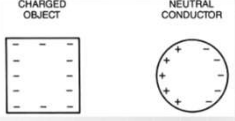

CHARGED OBJECT NEUTRAL CONDUCTOR

10

Inductive Charging

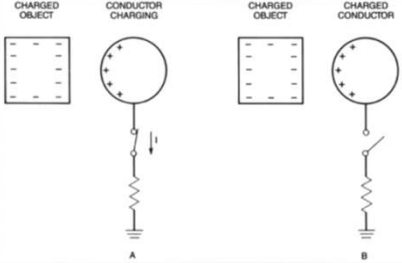

CHARGED OBJECT CONDUCTOR CHARGING CHARGED OBJECT CHARGED CONDUCTOR

A B

11

HUMAN BODY MODEL
Humans are a prime source of electrostatic discharge.

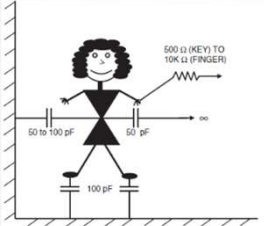

500 Ω (KEY) TO 10K Ω (FINGER)

50 to 100 pF 50 pF 100 pF

12

HUMAN BODY MODEL (EU 150pF/330Ohm)

The human body model (HBM) for ESD

RANGE OF VALUES	
C_b	50 to 250 pF
R_b	500 to 10k Ω
V_b	0 to 20 kV

HUMAN BODY MODEL

Typical wavelshape produced by a 150-pF, 330-ohm human body model discharge into a special 2 Ω test target

Air
Human Skin
Glass
Human Hair
Wool
Fur
Paper
Cotton
Wood
Hard Rubber
Acetate Rayon
Polyester
Polyurethane
PVC
PTFE

↑ Increasingly positive
Neutral
↓ Increasingly negative

a) (A version of) the triboelectric series b) Expected charge voltage (IEC 61000-4-2)

c) Equivalent circuit and waveform



University of Applied Sciences
and Technology

STATIC DISCHARGE

Charge accumulated on an object leaves the object by one of two ways, leakage or arcing.



16



University of Applied Sciences
and Technology

STATIC DISCHARGE

The minimum impedance that should be used in grounding a person is 250 kΩ. Grounded wrist straps usually have a 1 MΩ resistance to ground.



17

University of Applied Sciences
and Technology

STATIC DISCHARGE

Decay Time

The decay time (the relaxation time)

$$\tau = \frac{\epsilon}{\sigma}$$

or

$$\tau = \epsilon \rho$$

where ϵ is the dielectric constant for the material, σ is the conductivity and ρ is the surface resistivity.



18

Decay Time

Materials can be classified into four categories

Material	Surface Resistivity (Ω /Square)
Conductive	0 to 10^5
Static dissipative	10^5 to 10^9
Antistatic ^d	10^9 to 10^{14}
Insulative ^e	$> 10^{14}$

ESD PROTECTION IN EQUIPMENT DESIGN

ESD-induced effects in electronic systems can be divided into three categories:

1. **Hard errors**
2. **Soft errors**
3. **Transient upset**

ESD PROTECTION IN EQUIPMENT DESIGN

Effective ESD immunity design requires

First, prevent or minimize the entry of the transient currents by:

- Effective design of the enclosure
- Cable shielding
- Providing transient protection on all conductors of unshielded external cables

Second, harden sensitive circuits, such as:

- Resets
- Interrupts
- Other critical control inputs

Third, write transient hardened software capable of detecting, and if possible, correcting errors in the following:

- Program flow
- Input/output (I/O) data
- Memory

UNIVERSITÄT
DUISBURG
ESSEN
VIRTUeller
LEBENS
WISSENSCHAFTEN

ESD PROTECTION IN EQUIPMENT DESIGN

Energy from a static discharge can be coupled to an electronic circuit:

1. By **direct** conduction
2. By **field** coupling, including
 - a. Capacitive coupling
 - b. Inductive coupling



22

UNIVERSITÄT
DUISBURG
ESSEN
VIRTUeller
LEBENS
WISSENSCHAFTEN

ESD PROTECTION IN EQUIPMENT DESIGN

A circuit or system may be protected from a static discharge by any of the following:

1. **Eliminating** the static buildup on the source
2. **Insulating** the product to prevent a discharge
3. Providing **an alternative path** for the discharge current to bypass the sensitive circuits
4. **Shielding** the circuit against the electric fields produced by the discharge
5. **Decreasing loop areas** to protect the circuit from the magnetic fields produced by the discharge
6. **Apply TVS elements**



23

UNIVERSITÄT
DUISBURG
ESSEN
VIRTUeller
LEBENS
WISSENSCHAFTEN

PREVENTING ESD ENTRY

The three most common points of ESD entry are the enclosure, cables, and keyboards or control panels.



24

ESD GROUNDING

The first thing to remember about ESD grounding is that the ac power cord's green-yellow-wire ground is a high impedance at ESD frequencies.

The real ground or reference for ESD is the chassis (or metallic enclosure) or ESD ground plate within the product, and its free-space capacitance. Therefore, the way to divert the ESD current away from the circuit is to connect the input circuit transient voltage protectors, and/or filters, to the enclosure.



NONGROUNDED PRODUCTS

On a product with no external ground connection (e.g., a handheld calculator), the ESD current path will be from the entry point through the part of the product with the largest capacitance (i.e., lowest impedance) to ground. On many small handheld products, the part with the largest capacitance to ground is the printed circuit board. The solution is to provide an alternative path with lower impedance (larger capacitance) to ground for the ESD current to flow through. This is usually accomplished by adding a dedicated ESD ground plate to the product underneath the PCB.



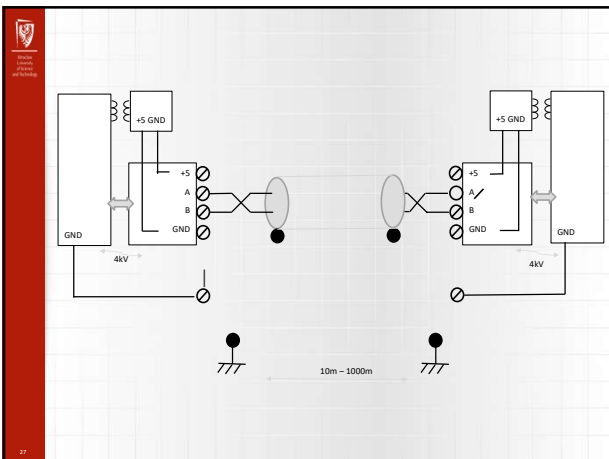

Digital GND and Chassis GND connected by the multipoints via a PCB Board. This should be done on the PCB board (not by wires).

Earth GND one point (with chassis GND)

PCB design. Digital GND should be removed under NET GND

This concept I have used the last 20 years and never failed (Am I lucky???)

Correct

TEXAS INSTRUMENTS SLLS897F - MARCH 2008

ISO1176 Isolated RS-485 Profibus Transceiver

1 Features

- Meets or exceeds the requirements of EN 50170 and TIA/EIA-485-A
- Signaling rates up to 40 Mbps
- Differential output exceeds 2.1 V (54 Ω load)
- Low bus capacitance – 10 pF (maximum)
- Up to 160 transceivers on a bus
- 50 kV/μs typical transient immunity
- Fail-safe receiver for bus open, short, idle
- 3.3 V inputs are 5 V tolerant
- Bus-pin ESD protection
 - 16 kV HBM between bus pins and GND2
 - 6 kV HBM between bus pins and GND1
- Safety and regulatory approvals
 - 4000 V_{PK} isolation, 560 V_{PK} V_{ORM} per DIN EN IEC 60747-17 (VDE 0884-17)
 - 2500 V_{RMS} isolation rating per UL 1577
 - 4000 V_{PK} isolation rating per CSA 62368-1

UL between the line transceiver an interface.

The galvanically isolated differential is an integrated circuit designed for communication on multipoint bus-485. The transceiver combines a galv differential line driver and differ receiver. The driver has an active-isolated enable-state output on the 10) to facilitate direction control. The outputs and the receiver differentia internally to form a differential input port that is designed to offer minimu bus allowing up to 160 nodes.

The PV pin (pin 7) is provided as i option. All device outputs become when a logic low is applied to the F information, see the function tables ir

6.2 ESD Ratings

	VALUE	UNIT
Human body model (HBM) per ANSI/ESD/JEDEC J88B-11	±6000	V
Machine model (MM) per ANSI/ESD/JEDEC J88B-11	±10000	V
Charged device model (CDM) per JEDEC specification JESD22-C101, all pins ¹⁾	±4000	V
Electrostatic Discharge (ESD) per IEC 61000-4-2	±1500	V
Machine model (MM) ANSI/ESD/JEDEC J88B-11	±200	V



ISO1450, ISO1452, ISO1410, ISO1412, ISO1430, ISO1432
 SLUS127C – APRIL 2016 – REVISED JUNE 2020

ISO14xx 5kV_{RMS} Isolated RS-485/RS-422 Transceiver With Robust EMC

1 Features

- Compatible with TIA/EIA-485-A
- PROFIBUS compatible at 5V bus-side supply
- Bus I/O protection
 - ±30kV HBM
 - ±16kV IEC 61000-4-2 Contact discharge
 - ±4kV IEC 61000-4-4 Electrical fast transient
- Low-EM 500kpps, 12Mbps and 50Mbps Data Rates
- 1.71V to 5.5V logic-side supply (V_{CC1}), 3V to 5.5V

3 Description

The ISO14xx devices are galvanically-isolated differential line transceivers for TIA/EIA RS-485 and RS-422 applications. These noise-immune transceivers are designed to operate in harsh industrial environments. The bus pins of these devices can endure high levels of IEC electrostatic discharge (ESD) and IEC electrical fast transient (EFT) events which eliminates the need for additional components on bus for system-level protection. The

7.2 ESD Ratings

			VALUE	UNIT
V _{ESD}	Contact Discharge, per IEC 61000-4-2	Pins Bus terminals and GND2	±15000	V
V _{ESD}	Contact Discharge, per IEC 61000-4-2	ISO141x, Pins Bus terminals and GND1 (across isolation barrier)	±8000	V
V _{ESD}	Contact Discharge, per IEC 61000-4-2	ISO143x, Pins Bus terminals and GND1 (across isolation barrier)	±8000	V
V _{ESD}	Electrostatic discharge (Human body model (HBM), per ANSI/ESD/JEDEC JS-001)	All pins except bus pins ⁽¹⁾	±6000	V
V _{ESD}	Electrostatic discharge (Charged device model (CDM), per JEDEC specification ESD2-C191)	Bus terminals to GND2 ⁽¹⁾	±30000	V
		All pins ⁽²⁾	±1500	



Test questions example:

1. What is the mechanism of static electricity generation ?
2. Draw a Human Body Model of ESD – with typical values of elements.

