

Experiment:

Operating amplifier – inverting & non-inverting amplifier, integrated & differentiating amplifier.

1. Objectives

The aim of the exercise is practical knowledge of the properties of operational amplifiers and their basic applications. The scope of practice includes the design and measurements of analog circuits with operational amplifiers.

2. Components and instrumentation.

On Figure 1a schematic of the system, PCB and op-amp pinout is shown. The same schematic can be applied for fundamental applications of operational amplifiers (amplifiers: inverting, non-inverting, differential, integrator, differentiator). Fig 1b shows a view of a printed circuit board.

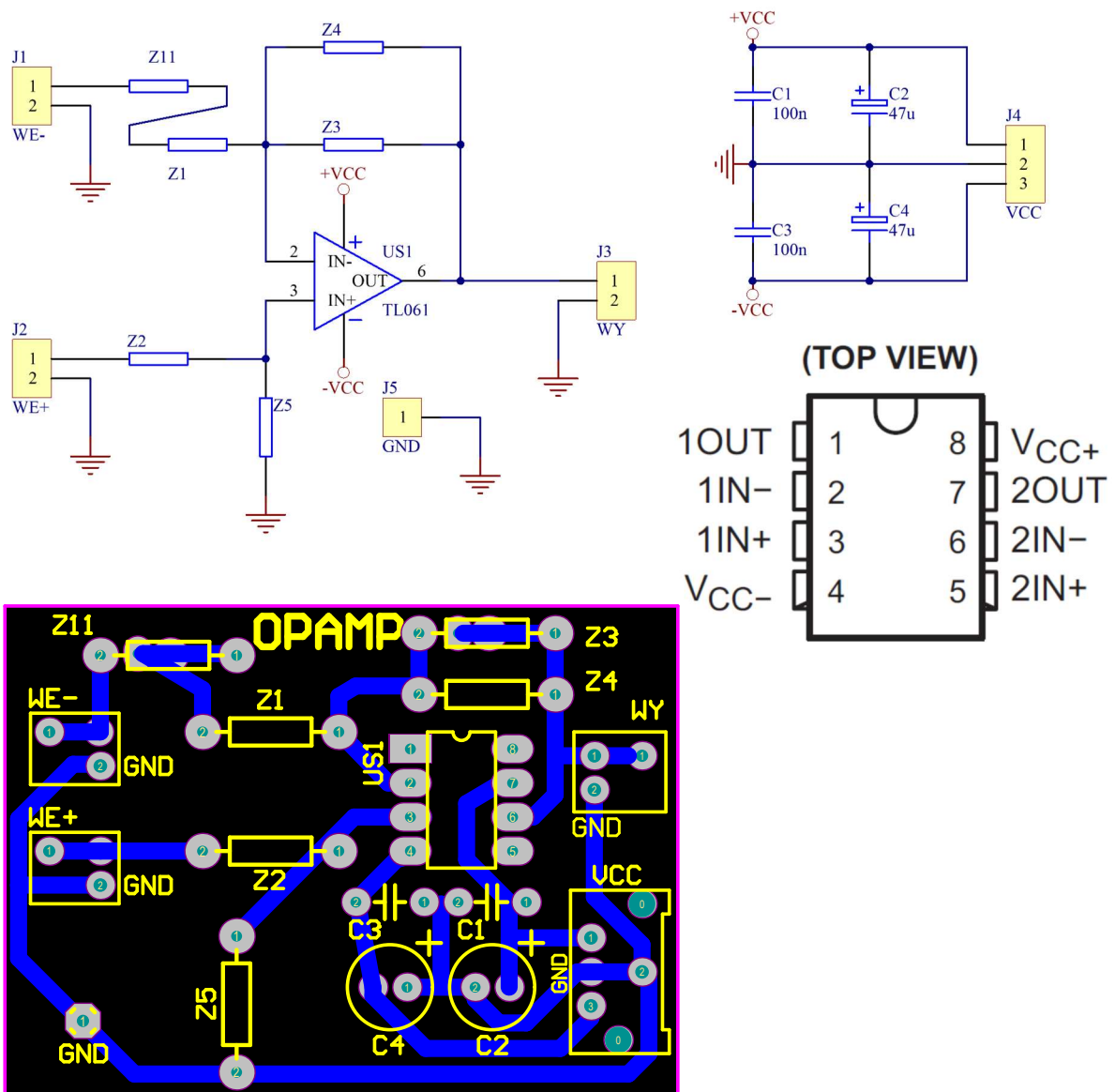

3. Preparation.

Estimated time for preparation is 3 to 6 hours.

3.1. Readings

- [1] W. Tietze, Ch. Schenk, Electronic circuits – Handbook for Design and Applications, Springer, 2008. Chapters 5.1, 5.2, 11.2, 11.3.11.4, 11.5.
- [2] TL061 data sheet <http://www.ti.com/lit/ds/symlink/tl064.pdf>, or <http://datasheet.octopart.com/TL064CN-Texas-Instruments-datasheet-11544566.pdf> or <http://www.st.com/web/en/resource/technical/document/datasheet/CD00000485.pdf>

3.2. Problems

1. Assuming perfect op-amp, what is the output voltage of the circuit (R_i and U_{in} are specified)?

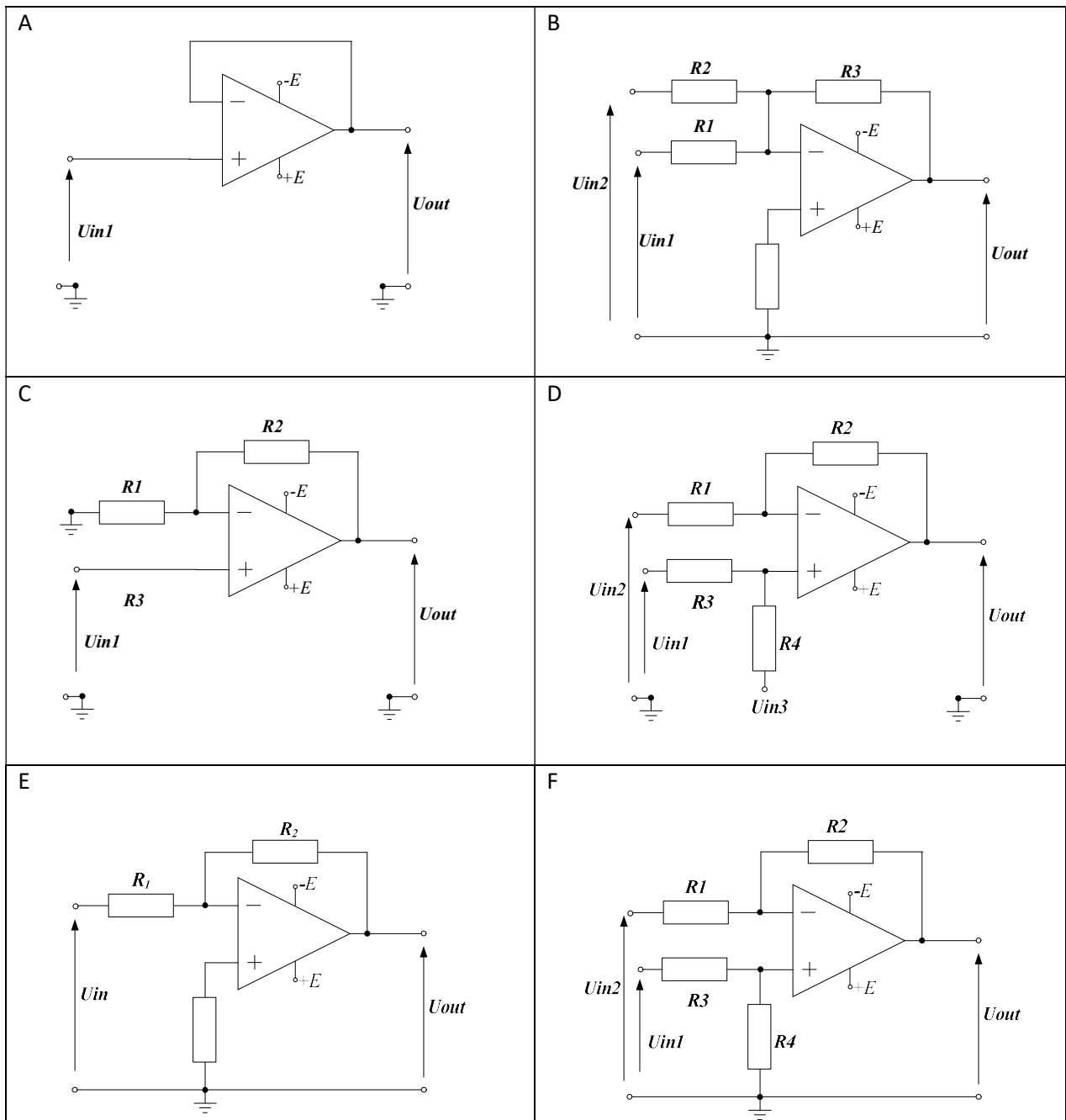

2. What is the offset voltage of an op-amp ?
3. Explain what is the CMRR coefficient ?
4. What is the SR (Slew Rate) coefficient ?
5. Derive the relationship between output and input voltages of an integrator.
6. Derive the relationship between output and input voltages of a differentiator.
7. What is the function of system transmittance and how to measure it ?
8. How calculate a transfer function in dB ?

3.3. Detailed preparation

Answer the above questions (problems) in a “laboratory notebook”.

All calculations related to the tasks below should be made in the notebook.

3.3.1. Inverting amplifier

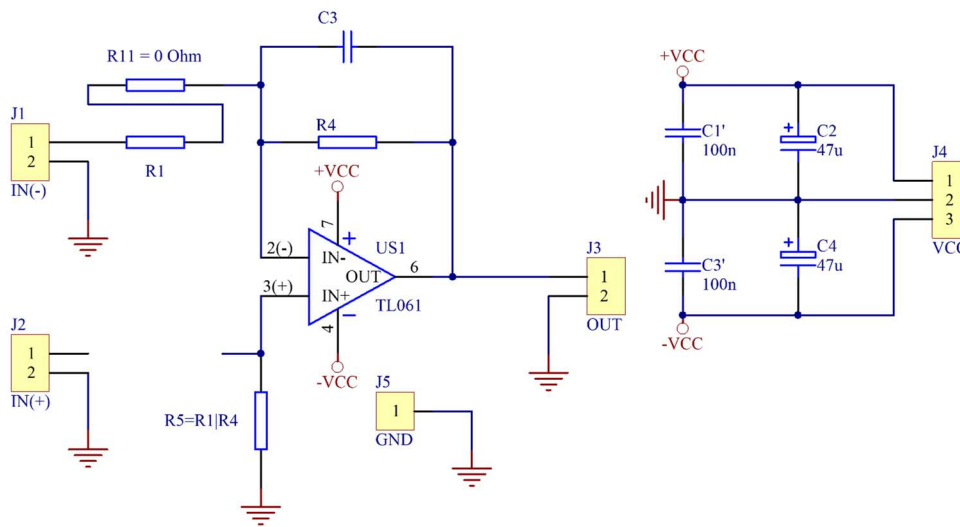

1. For circuit above diagram calculate R1 and R4 to achieve chosen gain =.....[V/V].
2. Calculate the upper cut-off frequency of the amplifier.
3. Estimate worst case offset.
4. Analyze (AC analysis) the circuit using any SPICE program (e.g. LTSPICE).

If parameters in previous points are not specified by your tutor, chose parameters from the table right for Your group:

Group	Gain [V/V]
1 and 7	-3
2, 8	-4
3, 9	-5
4, 10	-6
5, 11	-8
6, 12	-10

3.3.2. Non-inverting amplifier

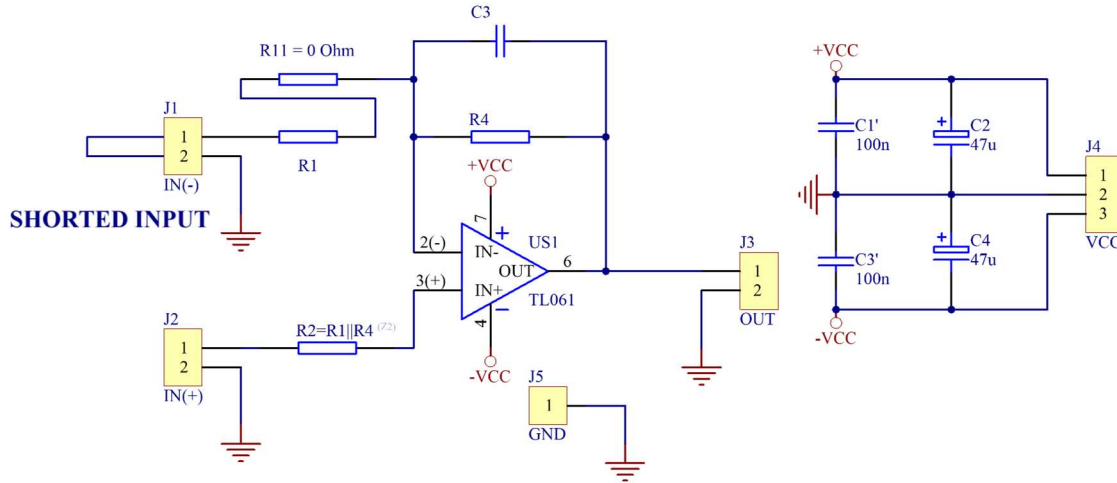

1. For circuit above diagram calculate R1 and R4 to achieve chosen gain =[V/V].
2. Calculate the upper cut-off frequency of the amplifier.
3. Estimate worst case offset.
4. Analyze (AC analysis) the circuit using any SPICE program (e.g. LTSPICE).

If parameters in previous points are not specified by your tutor, chose parameters from the table right for Your group:

Group	Gain [V/V]
1 and 7	10
2, 8	8
3, 9	6
4, 10	5
5, 11	4
6, 12	3

3.3.3. Integrator

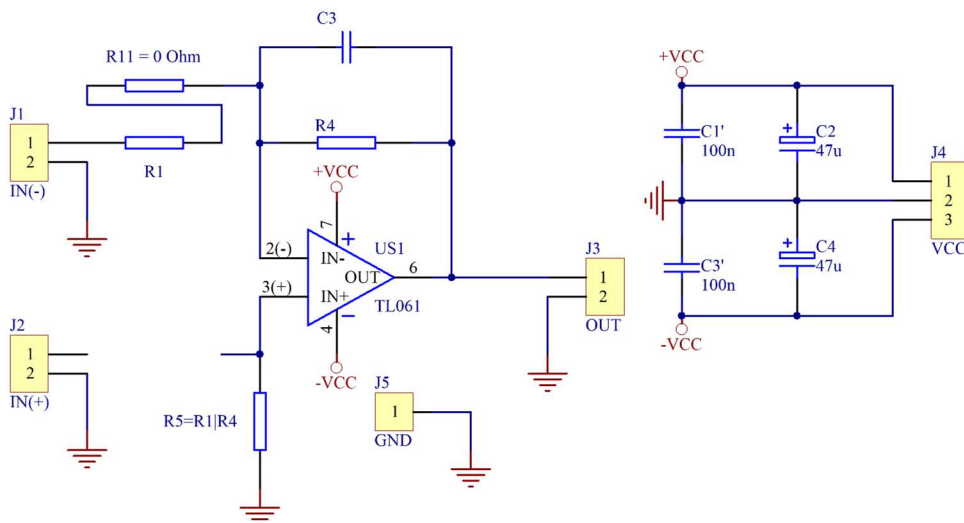

1. For circuit above diagram. calculate R1 ($R4 = 10 \div 30 * R1 \gg 100k$) and C3 (use C3 from the values: 360p, 1n, 1n5, 3n3, 4n7, 6n8, 10n, 15n), to achieve output triangle wave amplitude $U_{out} = \dots [V]$, when circuit is driven by square wave of the amplitude of $U_{in} = [V]$ and frequency $f = \dots [Hz]$.

- Analyze (Transient analysis) the circuit using any SPICE program (e.g. LTSPICE).
- Analyze (AC analysis) the circuit using any SPICE program (e.g. LTSPICE).

If parameters in previous points are not specified by your tutor, chose parameters from the table right for Your group:

Group	Uin [V] (square)	Uout [V] (triangle)	F [Hz]
1 and 7	2	4	800
2, 8	3	3	800
3, 9	2	4	1000
4, 10	3	3	1000
5, 11	2	4	900
6, 12	3	3	900

3.3.4. Differentiator

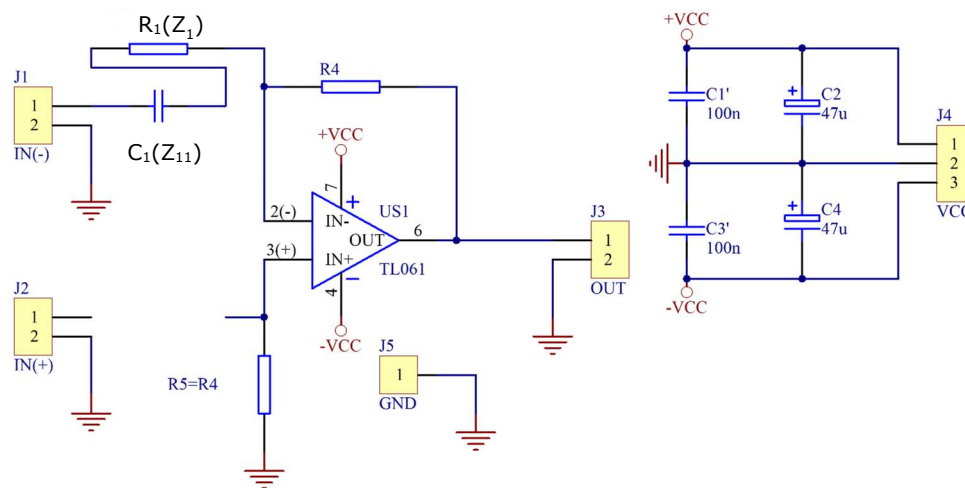

- For circuit above Fig. calculate R4 and C1 (use C1 from the values: 240p, 360p, 1n, 1n5, 3n3, 4n7, 6n8, 10n,), to achieve output square wave amplitude $U_{out} = \dots [V]$, when circuit is driven by triangle wave of the amplitude of $U_{in} = \dots [V]$ and frequency $f = \dots [Hz]$.

R1 choose to fulfil the eq. $\frac{1}{2\pi R_1 C_1} < \sqrt{f_T \times \frac{1}{2\pi R_4 C_1}}$ where f_T is the op-amp unity gain frequency (for TL061 about 1MHz).

- Analyze (Transient analysis) the circuit using any SPICE program (e.g. LTSPICE).
- Analyze (AC analysis) the circuit using any SPICE program (e.g. LTSPICE).

If parameters in previous points are not specified by your tutor, chose parameters from the table right for Your group:

Group	Uin [V] (triangle)	Uout [V] (square)	F [Hz]
1 and 7	2	4	900
2, 8	3	3	900
3, 9	2	4	1000
4, 10	3	3	1000
5, 11	2	4	800
6, 12	3	3	800

4. Contest of rapport

4.1.1. Inverting amplifier

1. Voltage transfer function graph (amplitude in dB and phase, frequency - logarithmic axis) for two cases:
 - a. Without capacitor C3,
 - b. With capacitor C3=1nF,
 - c. Depicted cut-off frequencies for both graphs and comparison with that calculated.
2. As in point 1, analyzed using SPICE type program,
3. Offset measured.
4. Slew rate of the amplifier reading and appropriate oscilloscope screen shot (compare the measured SR with that from data sheet).

4.1.2. Non-inverting amplifier

1. Voltage transfer function graph (amplitude in dB and phase, frequency - logarithmic axis) for two cases:
 - a. Without capacitor C3,
 - b. With capacitor C3=1nF,
 - c. Depicted cut-off frequencies for both graphs and compare with that calculated.
2. As in point 1, analyzed using SPICE type program,
3. Offset measured.
4. Slew rate of the amplifier reading and appropriate oscilloscope screen shot (compare the measured SR with that from data sheet).

4.1.3. Integrator

1. Voltage transfer function graph (amplitude in dB and phase, frequency - logarithmic axis). Mark the band width of the correct operation of the integrator.
2. Screen shot of input and output waves as in the task 3.3.3.
3. The same from SPICE program transient analyze.

4.1.4. Differentiator

1. Voltage transfer function graph (amplitude in dB and phase, frequency - logarithmic axis); Mark the band width of the correct operation of the differentiator.
2. Screen shot of input and output waves as in the task 3.3.4.
3. The same from SPICE program transient analyze.